

# Domestic Nuclear Shelters

## Advice on domestic shelters providing protection against nuclear explosions



### A Home Office Guide

## Domestic Nuclear Shelters

This booklet is a brief guide to three basic kinds of nuclear shelter:

- Simple shelters for short-term indoor or out-door use which can be built from materials already at hand.
- Shelters that can be assembled from do-it-yourself kits.
- Permanent custom-built shelters built into the ground and requiring professional help in design and construction.

### Further information

Additional information about protection from nuclear attack is to be found in the booklet [Protect and Survive](#) available from Her



[The likely effects of a nuclear attack](#)

### [Types of shelters](#)

[1a](#) [Easily-constructed garden shelter](#)

[1b](#) [Improvised outdoor shelter](#)

[2](#) [Indoor shelter from manufactured kit](#)

[3](#) [Outdoor shelter from a manufactured kit](#)

[4](#) [Permanent purpose-built shelter](#)

[Stocking your shelter](#)



Majestys Stationery Office and main booksellers or by post from HMSO bookshops.

Detailed technical guidance on shelter design and Construction is available in *Domestic Nuclear Shelters- Technical Guidance* published by HMSO. More detailed description of the effects of nuclear weapons can be found in *Nuclear Weapons* published by HMSO.

## The likely effects of a nuclear attack

### Light and heat

A nuclear explosion produces an intense flash of light lasting some seconds which would blind anyone seeing it. The heat flash can set fire to buildings up to some distance from the centre of the explosion depending upon the haziness of the atmosphere at the time. Skin exposed to the heat flash could suffer burns. But any shelter that withstands the blast would give protection against the heat flash. Any exposed parts of the shelter made of flammable material could catch fire. Exposed plastic would not catch fire but might distort in the heat and this could weaken the resistance of the shelter to the subsequent blast wave.

### Initial nuclear radiation (INR)

This very penetrating radiation is emitted from the fireball within one minute of the explosion. The distances from one megaton explosions and above, at which people require shielding from INR, are less than those distances at which there would be total destruction.

### Blast

At the moment of explosion a blast wave would be generated, travelling at a tremendous speed and creating extremely strong winds which may last for several seconds. When the blast wave passes over a building the sudden increase of pressure and the following wind may cause the building either to explode or collapse.

### Tremors

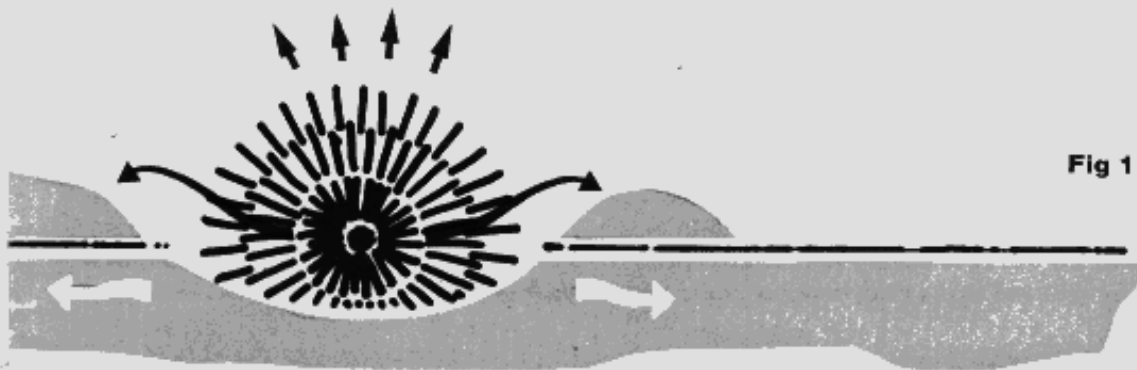
The tremors or shock waves from a ground blast extend for a short distance only and would not affect buildings beyond those already destroyed by the blast. The effect on shelters below the ground would depend on their ability to withstand ground movement and on the nature of the soil. Depth in the ground, shape and flexibility would be important.

### Fallout

An explosion on or near the ground sucks up a large amount of earth and debris, which is vaporised as it rises to a great height and becomes highly radioactive. It then condenses to sand-like particles which are carried along by the wind and drop to the ground. This fallout can come down very near to the explosion or may be carried by the wind for hundreds of miles. The fallout dust is usually visible to the naked eye, but it emits ionising radiation rather like X-rays, which cannot be seen or felt. Radiation is dangerous and heavy doses cause sickness or death. Fallout dust remains radioactive for some days after the explosion - and can, in certain circumstances, still be dangerous after several weeks.

## Bombs exploding on or near the ground

When a nuclear weapon explodes on or near the ground, a shock like a small earthquake goes through the ground. The earth vaporised into the fireball leaves a crater around the site of the explosion. The vaporised earth falls to the ground from half an hour to up to about a day later as radioactive fallout.



## Bombs exploding in the air

When a nuclear bomb explodes in the air the blast effect is more marked. The area affected will be about 30 per cent greater than a ground burst bomb of the same size. But with air-burst weapons there is no dangerous radioactive fallout - since the fireball does not touch the ground no earth is sucked up.

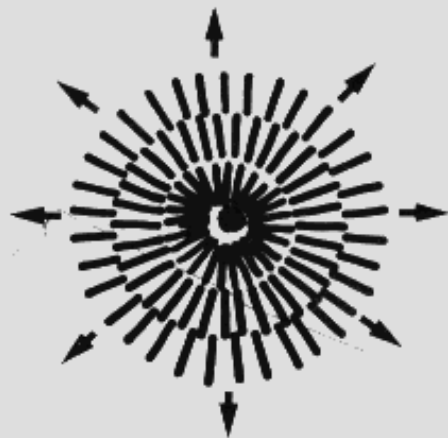
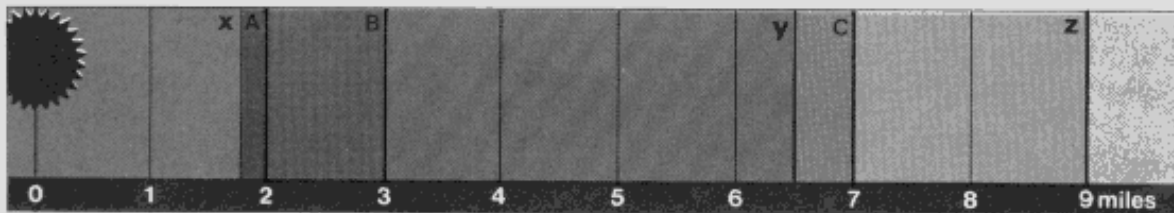


Fig 2

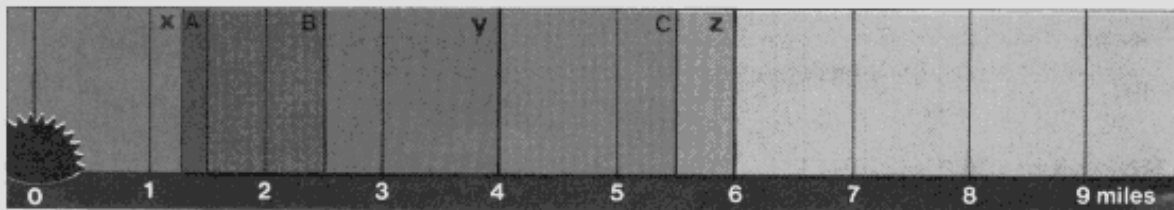


Fig 3 - The extent of blast, fire and INR effects

Air burst (1 megaton)



Ground burst (1 megaton)



Limit of:	<b>A</b> Total destruction	<b>x</b> Approx. range of INR within which shielding is vital	<b>z</b> Blistering to exposed skin
	<b>B</b> Irreparable damage	<b>y</b> Fire zone	
	<b>C</b> Severe/moderate damage		

## What happens to fallout after a nuclear attack

It is important to remember that the radiation emitted from fallout decreases as time passes, very rapidly at first and more slowly later. For example, after seven hours the radiation emitted will have fallen to one tenth of its strength and after two days to one hundredth.

When the intensity has fallen sufficiently it will be safe to emerge from your shelter for short periods. You will be advised by radio when this is, and for how long you can stay outside. At first it might be safe to spend only an hour or so a day in the open but this safe period will gradually increase until it becomes safe to stay outside all the time. Even in the worst affected areas it might be safe to leave the shelter altogether after about two weeks and in most places this period would be very much shorter.

When outside the shelter no special clothing is required, but it would be advisable to wear outdoor clothing and wellington boots or stout shoes to avoid contamination of your indoor clothes. You should remove these clothes before re-entering the shelter.

The shelters described later on in this booklet offer differing degrees of protection against blast and against fallout. They will also provide protection against the heat flash provided no flammable materials are exposed. No shelter is capable of protecting someone close to the site of a nuclear explosion, but for those who are far enough away to survive the initial effects. The principal danger after the explosion is from radioactive fallout.

Dense material around a shelter will lessen the risk of harm from radiation so long as you remain inside. Essentially the thicker the material the better the protection. But some protective materials are more effective than others.

Below is a list of common materials likely to be used in the construction of a shelter. Their value as protection against radiation is given in terms of the thickness required to reduce radiation by one half thus 2 in. of lead gives the same protection as 3 1/2 in. of slates.

The protection given by buildings or shelters can be expressed as a *protective factor*. A typical house will reduce the power of the radiation to one fifteenth of that outside - this is called a protective factor of 15. Shelters constructed of the right materials can give a much greater protective factor than this.

### Some relative protection values

	Inches		Inches	
LEAD	0.5	STONE	2.2	<b>Increased thicknesses of material reduce the intensity of ionising radiation. For example, each 2.2 in. of concrete reduces the intensity by half, so a thickness of 8.8 in. of concrete would reduce the radiation to one sixteenth of its original</b>
STEEL	0.7	BRICKWORK	2.8	
TILES	1.0 to 1.9	SAND	2.9	
CORRUGATED ASBESTOS SHEET	2.0	EARTH	3.3	
		PLASTER	3.5	

ASPHALT	2.2	SLATES	3.5	<b>intensity.</b>
CONCRETE	2.2	WOOD	8.8	

## The overall picture

If there were a nuclear attack, it is likely that some bombs might burst in the air, and some on or near the ground. Estimates suggest that around 5 per cent of the land area of the UK might suffer seriously from the effects of blast. We cannot, of course, know in advance where the bombs would fall, but about 80 per cent of the land area might suffer no blast effects at all. Any part of the country might suffer fallout therefore radiation protection would be needed everywhere.

## Types of shelters

The section that follows describes four different types of shelter, the kind of protection they offer, and where they can be sited. The examples illustrated are from the detailed designs in *Domestic Nuclear Shelters - Technical Guidance*. It may be possible to vary the materials or the methods of construction shown in this booklet, without reducing the degree of protection provided, but if you propose to do so, check that your shelter will still conform to the guidance in that publication. If you decide to consult someone about a shelter you should check that they are professionally qualified, preferably as an architect or chartered civil/structural engineer. The Home Office proposes to publish further designs later. These designs will probably include at least one using glass reinforced plastic (fibre glass).

	<b>Type 1 Improvised</b>	<b>Type 2 Indoor kit</b>	<b>Type 3 Outdoor kit</b>	<b>Type 4 Purpose built</b>
Blast Protection psi (pounds per square inch)	Up to 1.5	Up to 6	Up to 11	In excess of 11
Fallout Radiation Protection Factor	Not less than 40	Not less than 70	Not less than 200	In excess of 300. Also protects against INR
Distance from a one megaton air burst beyond which shelter will remain intact	7 miles	3 miles	2 miles	Closer than 2 miles depending on design
Ventilation	Natural	Natural or forced	Forced	Forced
Site of installation	In house or garden	In house	In garden. Sectional for access through house	In garden. Appropriate access to garden necessary
Forethought and planning	<b>Install in crisis.</b> Some materials can be prepared in advance	Obtain in peace-time. <b>Install in crisis</b>	Obtain in peace-time. Install in peace time or crisis (Can be installed as a permanent shelter)	Install in peace-time using professional advice and help

Approximate expected cost (1980)	Nominal if using local materials: scaffold frame about £250	Kit £500-£800 Bricks £300	Kit £900-£1800 Plus any installation costs	£6000-£10,000 (but more sophisticated designs would obviously cost more)
----------------------------------	---	------------------------------	---	--

- A garden shelter should preferably be at least half the height of the nearest house away to avoid debris from collapsed buildings. It should also be away from large trees. Before removing earth check that you cannot damage drainage or other services.

### Planning permission, Building Regulations and rating

If you wish to install a permanent shelter you may need permission. You should check the regulations *before submitting plans or beginning work*. Your local District Council will tell you about planning permission and the Building Regulations. A permanent shelter may affect the rateable value of your home, and this is a matter for your local District Valuer and Valuation Officer (Regional Assessor in Scotland).

## Type 1a

### Easily-constructed improvised garden shelter using household materials

This shelter is suitable for areas where under ground shelters are impracticable, for example, where there is a high water table, so that a deep hole fills with water. It can be constructed using only materials which are generally available, and could be *built in a time of crisis*. It would take two people about 24 working hours each to build.

The shelter consists of a shallow trench dug into the ground with a roof of doors or sheet timber that is supported above ground level by earth walls. The structure is then covered by at least 18 in. of earth.

This basic design will give good protection from fallout radiation particularly if the occupants keep away from the entrance area. If, in addition, a barrier of sandbags or packed soil is built about two feet in front of the entrance, and to the same height, the protection in the entrance area will be improved.

### Construction

1. Select a site on level ground where there is little chance of rainwater collecting.

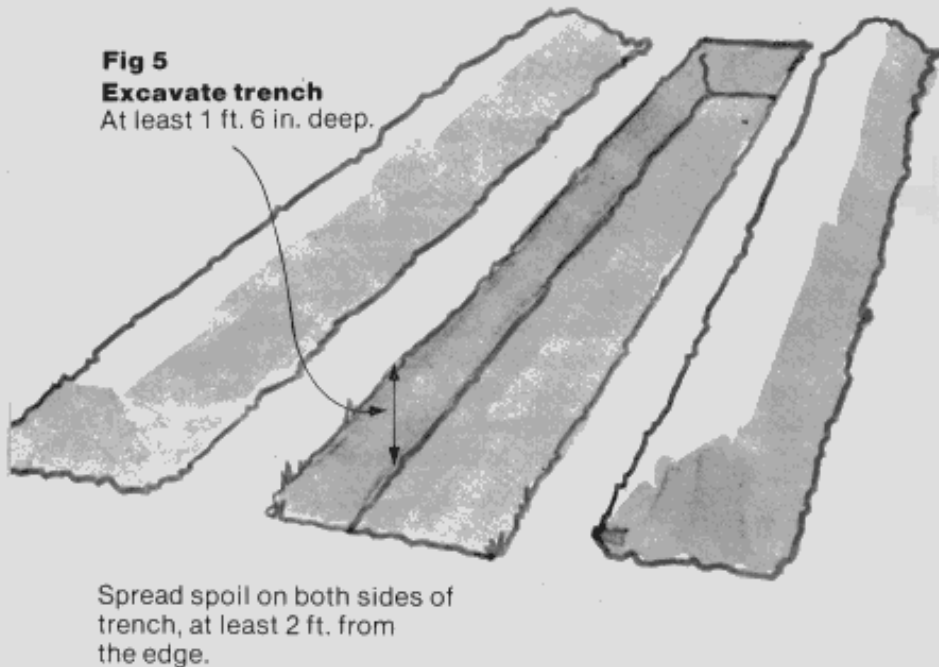
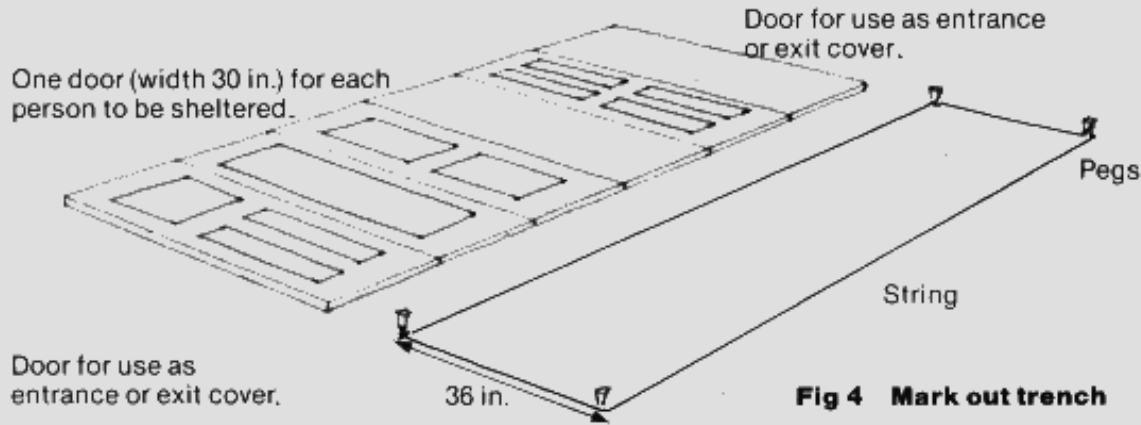
2. You will need:

- i. Pick, shovel or spade (preferably both), wheelbarrow or buckets, saw, screw-driver, knife, tape measure, pencil and paper, and a pair of gloves.
- ii. Pieces of large sheeting material. e.g. carpets. blankets. sheets, heavy duty polythene, sacking etc. for making earth rolls (Fig 7).
- iii. Plastic bags or pillowcases for making sandbags.
- iv. Timber: pieces of 2 in. x 4 in. wood at least 3 ft long are most useful although any suitable strong timber could be used for the cross braces (Fig 6). Floor-boards about 4 ft long could be used for entrance and exit tunnels (Fig 13).
- v. Nails: 100 x 2 in. steel nails, 30 x 4 in. steel nails.

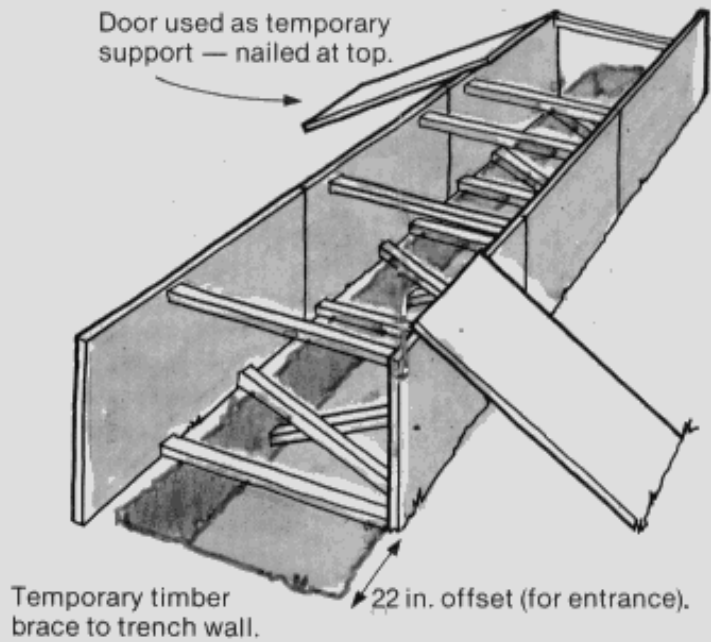
- vi. Doors: one door (normally about 30 in. wide) per person is required, together with one door each for entrance and exit. Fittings such as handles should be removed. If you do not have enough doors, sheet timber can be used.
- vii. Rainproofing material to cover the doors, e.g. polythene sheeting, shower curtains and vinyl floorcovering .
- viii. Pegs and string for markers and tying sandbags.

3. Construct the shelter as shown in Figs 4-14.

4. Furnish the shelter as required.





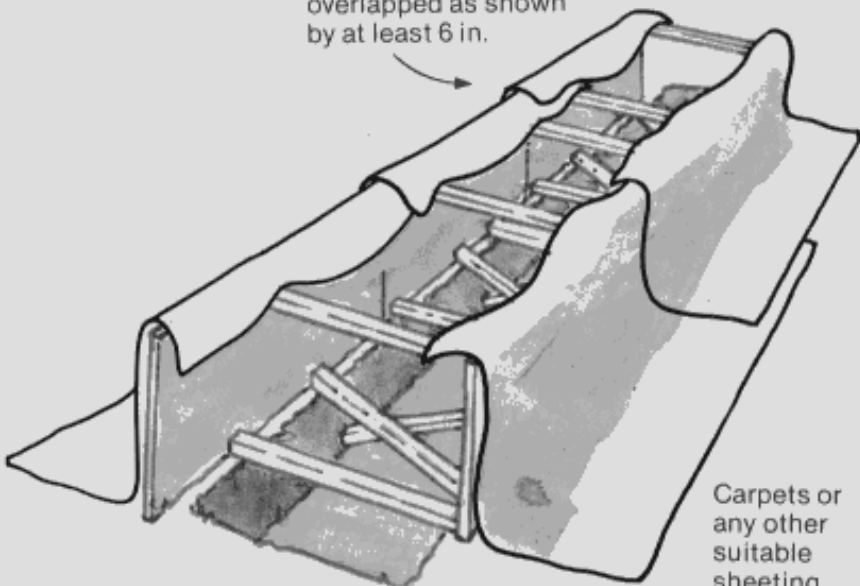


**Fig 6 Construct temporary walls**

40 in. by 2 in. temporary timber braces between doors.

Doors in position - construct temporary supporting structure of doors and timber against which earth rolls can be built (frame is removed later and doors, then used to form a roof).

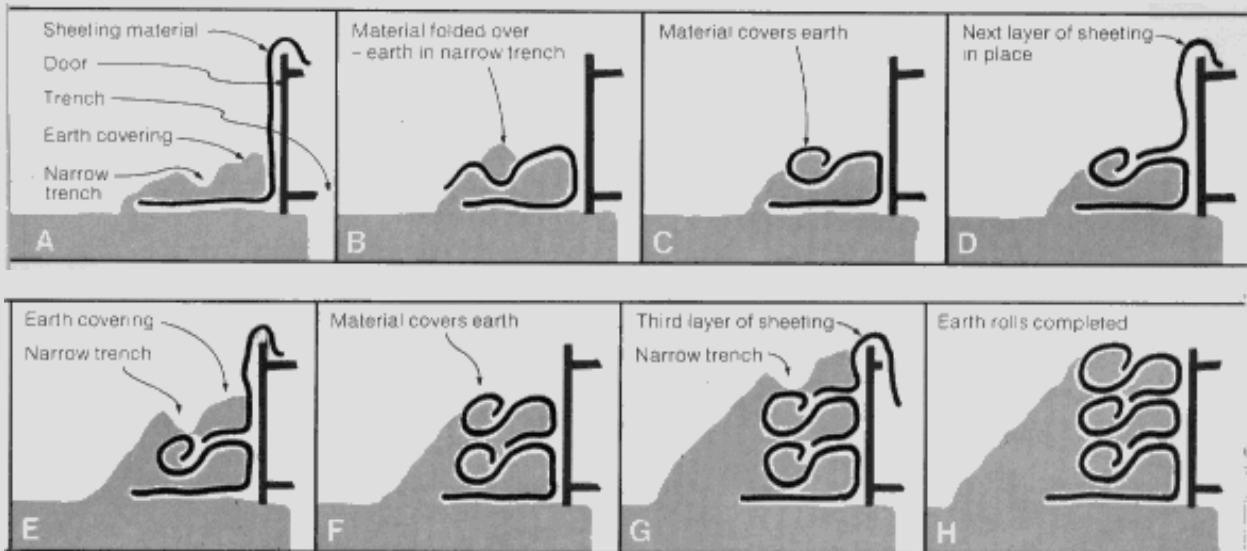
Material should be overlapped as shown by at least 6 in.



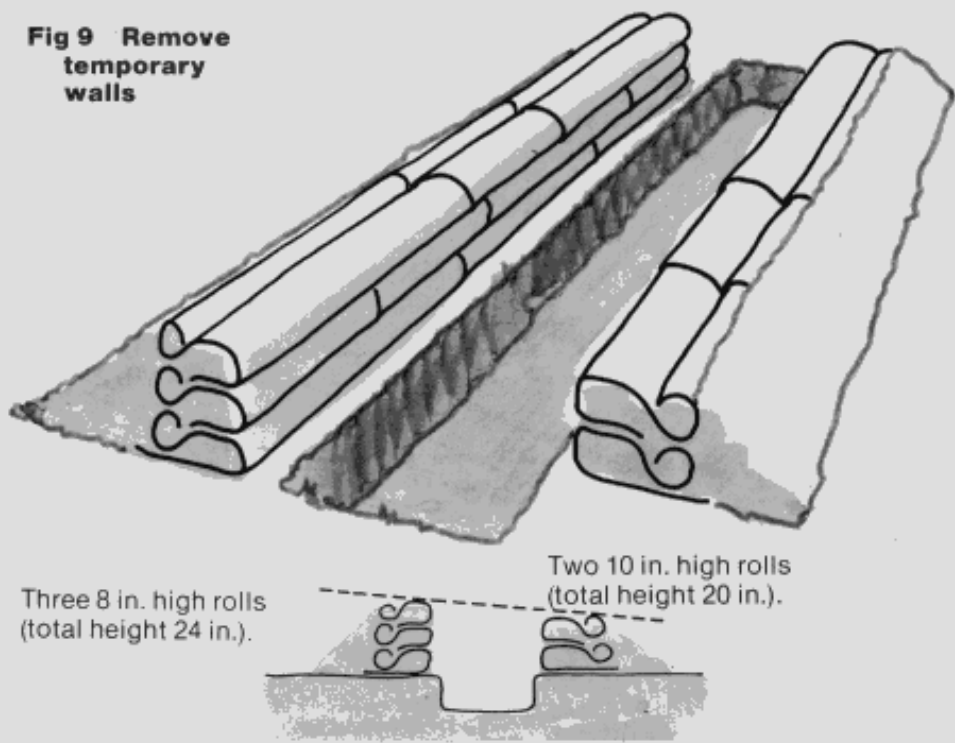
**Fig 7 Position sheeting material**

Carpets or any other suitable sheeting materials.

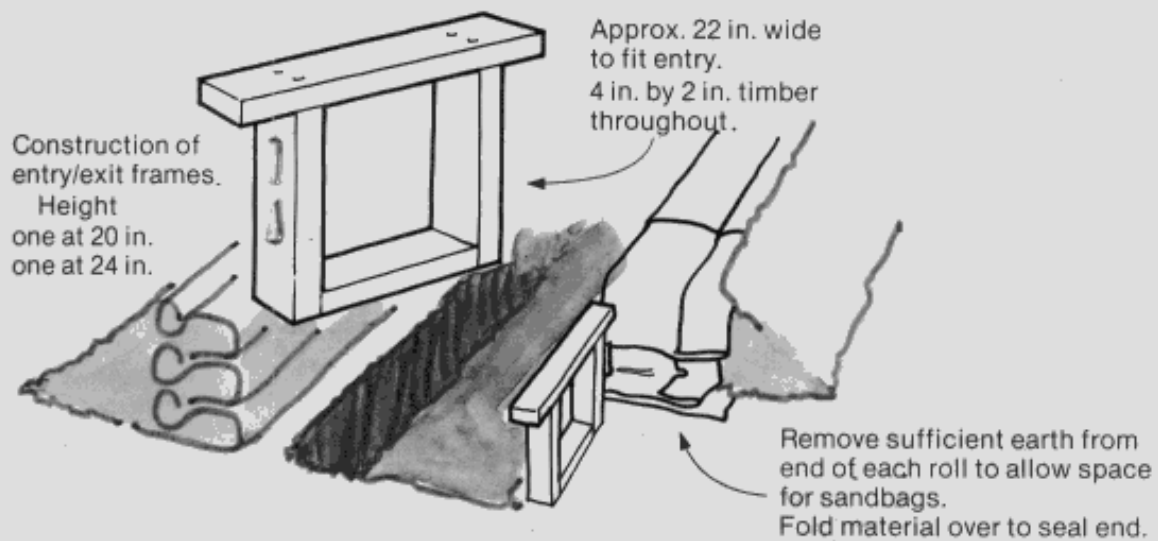
**Fig 8 - Construction of earth rolls**



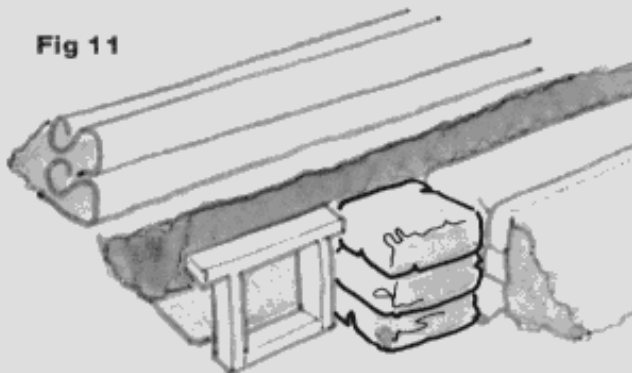
**Fig 9 Remove temporary walls**



**Fig 10 Construct entry/exit frames**

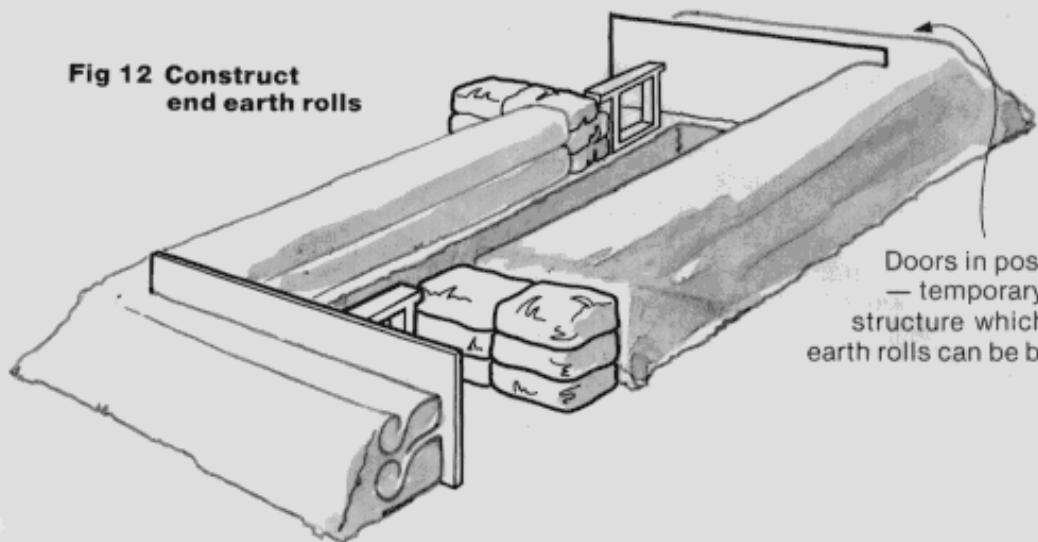


**Fig 11**



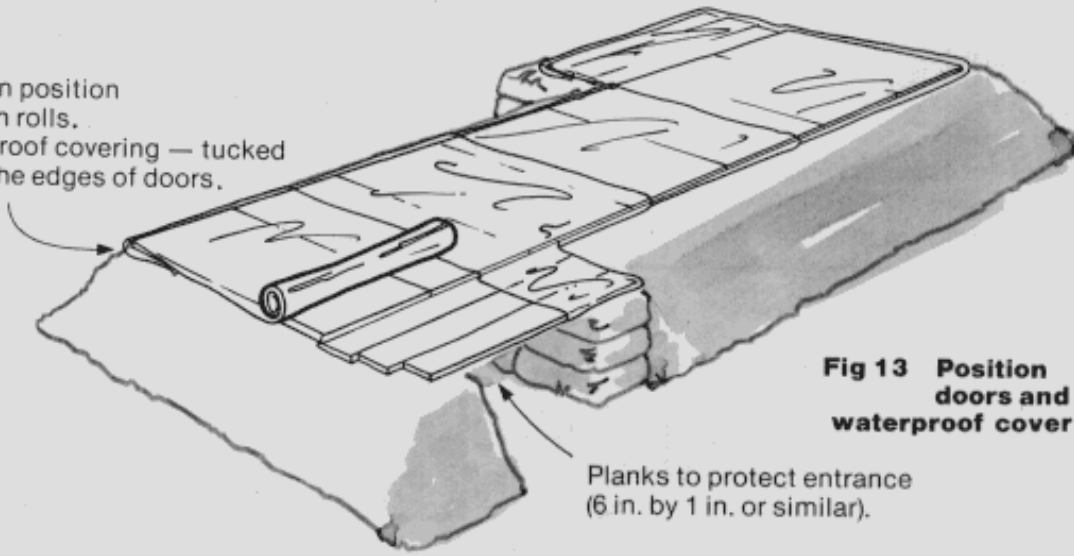
Sandbags will hold material in folded position.

**Fig 12 Construct end earth rolls**



Doors in position — temporary supporting structure which end earth rolls can be built against.

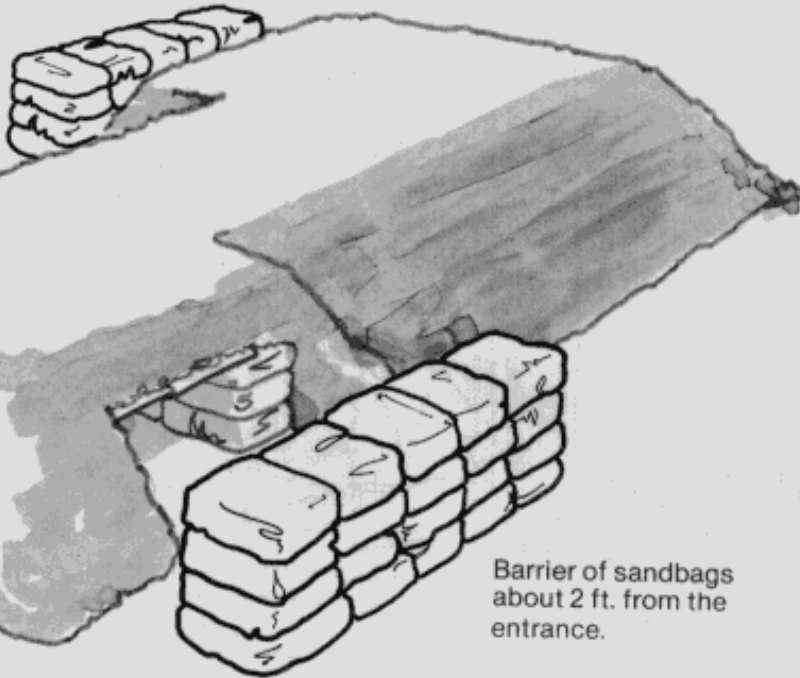
Doors in position  
on earth rolls.  
Waterproof covering — tucked  
under the edges of doors.



**Fig 13** Position  
doors and  
waterproof cover

Planks to protect entrance  
(6 in. by 1 in. or similar).

Earth spread over  
the door panels  
to at least 18 in. thick.



**Fig 14**  
Finish structure  
with earth cover

Barrier of sandbags  
about 2 ft. from the  
entrance.

# Type 1b

## Improvised outdoor shelter using do-it-yourself materials

The following diagrams show how a basic shelter can be constructed from standard scaffold poles and other materials available from builders merchants, timber yards and do-it-yourself stores.

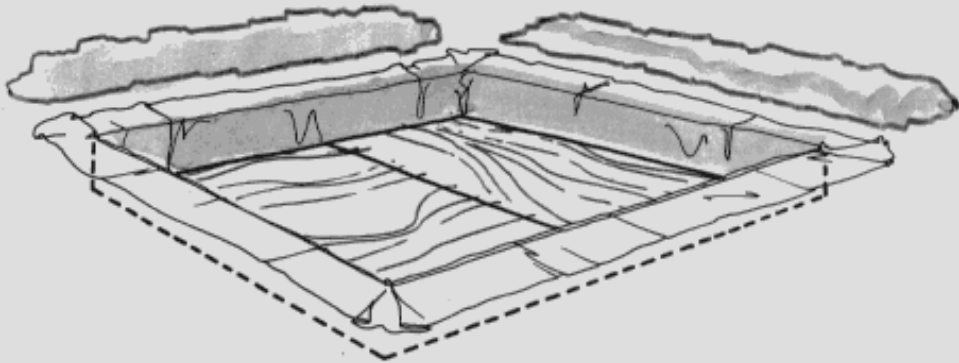
This type of shelter could be constructed in a time of crisis from materials previously purchased and stored. It would take two people about 24 working hours each to build this shelter - the size is adaptable.

The dimensions given would accommodate a family of four for a short period or two people plus provisions for longer.

This shelter uses steel or alloy, standard diameter scaffold poles. These are arranged in a series of 'A' frames over a trench. It is necessary to brace the frames with further scaffolding both diagonally along its length and across the waists of the 'A' sections to give rigidity. In both cases proprietary clamps are the best method of securing the scaffold poles to each other.

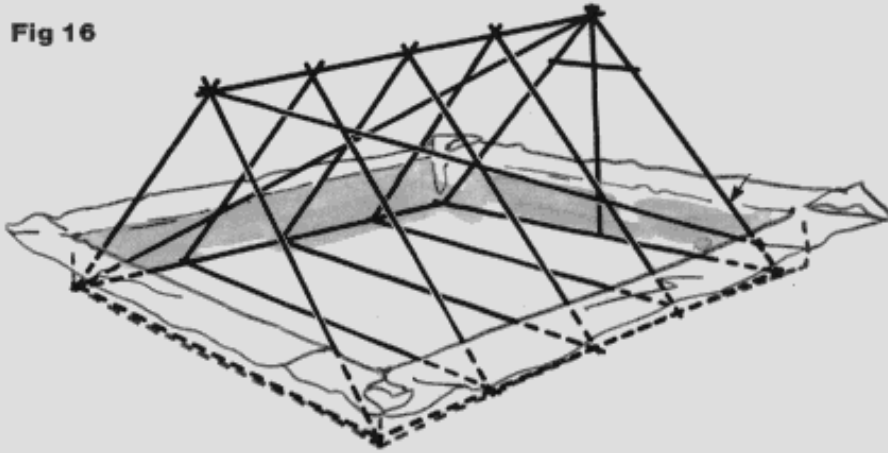
Prepare a trench 8 ft. x 8 ft. and at least 1 ft. 6 in. deep. Line it with heavy duty polythene sheeting. Lay a floor of two sheets of plywood, 3/4 in. thick and 4 ft. x 8 ft.

**Fig 15**



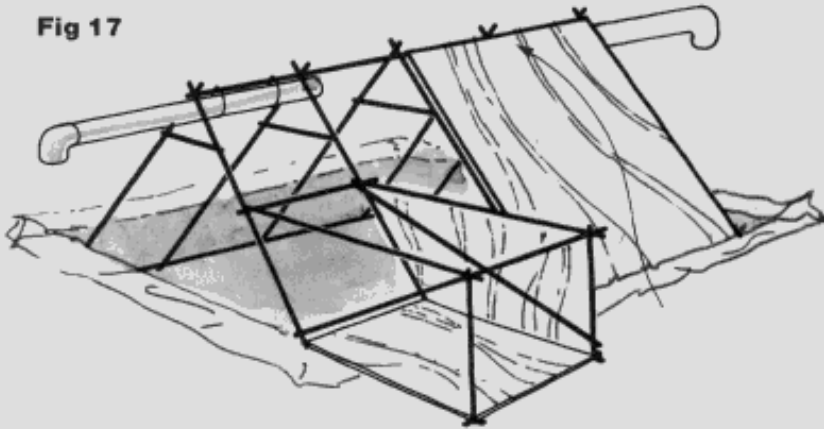
Construct the frame of scaffold poles (or you could use wood). This should be as strong as you can make it. You can increase the strength with vertical and diagonal bracing, or crossbars.

**Fig 16**



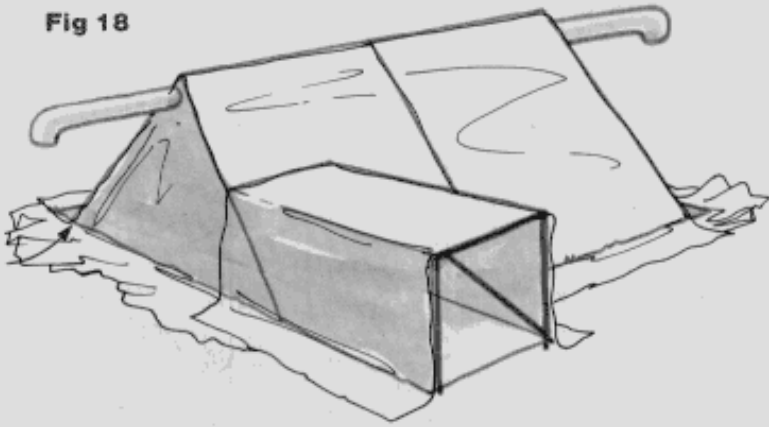
Add the frame for the entrance tunnel, and also the ventilation pipe (described opposite). Cover the entire frame (except the entrance hole) with plywood boarding. Any small gaps or sharp edges should be covered with carpet or thick fabric.

**Fig 17**



Wrap the shelter with overlapping sheets of heavy duty polythene. Make sure the trench lining is within this cover.

Fig 18



Finally, cover the shelter with a thick layer of earth (about 18 in.). The earth removed from the trench may not be enough for this. If you decide to dig a deeper initial trench to get enough earth to cover, you may need to make some modifications to the design given here.

The shelter will give better blast protection if you put a layer of resilient material between the polythene and the earth covering. Straw, mattresses, or similar, would be suitable.

The entrance can be filled from within with small bags of sand or earth. You will have to store these inside the shelter.

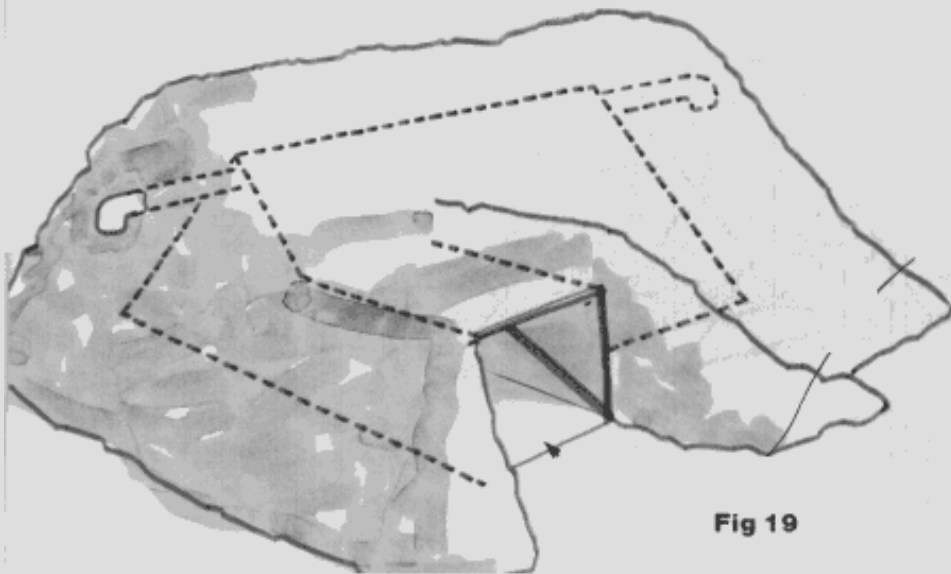


Fig 19

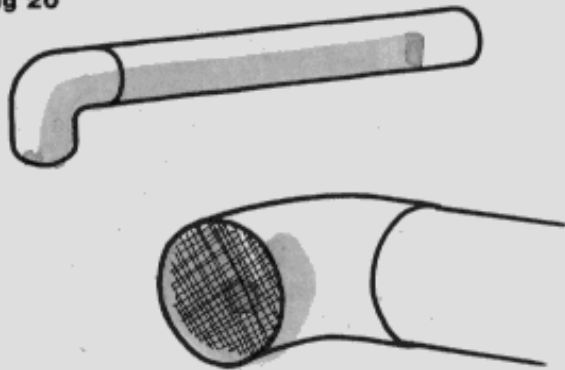
## Ventilation

For this shelter you will need to make some provision for ventilation. The diagrams show metal drainpipes with a bend near the opening, so that this faces downward. The opening should then be filled with a filter of steel wool. It is extremely important to ensure



that ventilation pipes are secure and kept free of obstruction.

Fig 20



The following two designs are intended to be sold by manufacturers as kits together with installation instructions. Design drawings are to be found in *Domestic Nuclear Shelters - Technical Guidance*.

## Type 2

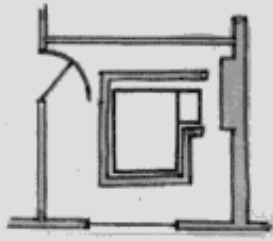
### Indoor shelter from manufactured kit

This type of shelter - basically a protective steel table - is suitable for homes that have basements or rooms that can be converted into 'fallout rooms' (described in *Protect and Survive*) provided that the floor is strong enough to support it.

This shelter will sustain the debris load resulting from the complete collapse of a normal two-storey house. To obtain protection from fallout, it must be surrounded with dry-laid bricks, sand or earth bags or heavy furniture filled with sand, earth or books.

The shelter is designed to accommodate two adults and two children. Two shelters or more may be put together to increase the capacity.

It would take two people about two hours to erect the shelter itself and up to an additional 20 hours to surround it with protective material.



Plan of shelter in 'fallout room'.

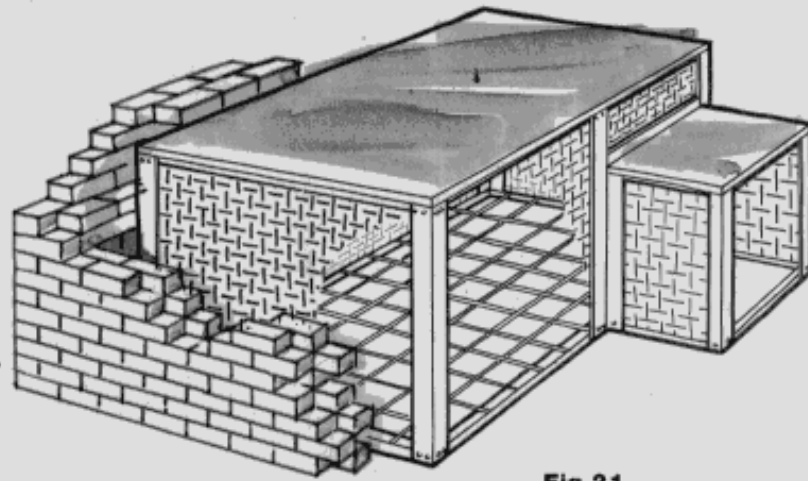


Fig 21

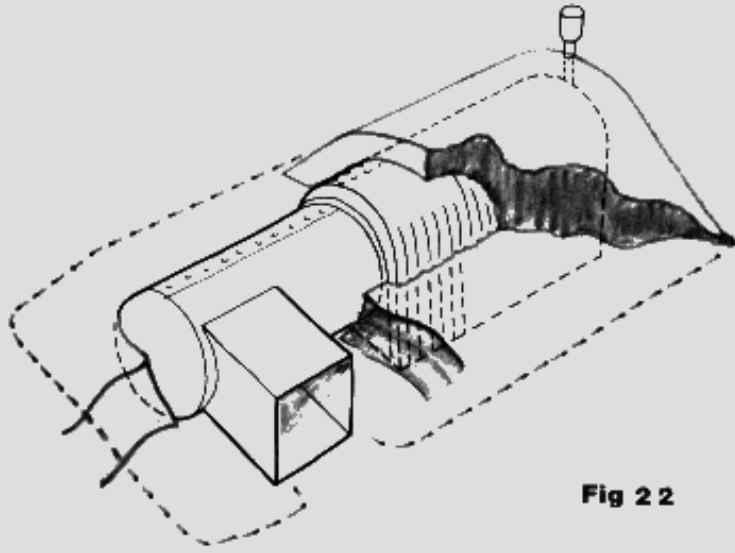
## Type 3

### Outdoor shelter from a manufactured kit

This type of shelter is generally suitable where there is a garden or other convenient land near the living accommodation. It is formed by building a strong structural shell with prefabricated steel components bolted together to form a sealed room of sufficient size for up to six people. The shell is semi-sunk in the ground and covered entirely by earth from the excavation.

There will be variations both in materials and construction depending upon the costs. The assembly of the shell would take a full days work for two people. The excavation could, however, take at least a week for two people digging by hand.

While the kit could be bought in readiness and digging and installation done over a period of time the materials would have to be non-corrosive, and not likely to deteriorate.



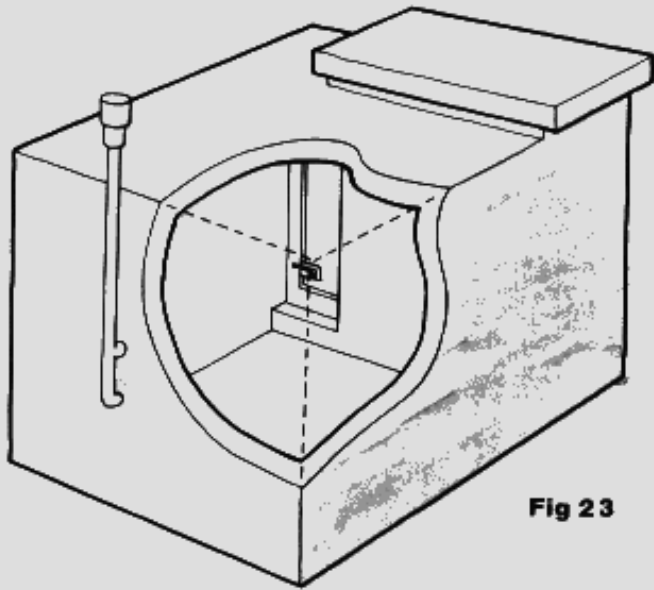
**Fig 2 2**

## Type 4

### Permanent purpose-built shelter

This reinforced concrete shelter must be erected by a building contractor under the guidance of a chartered civil/structural engineer. It should on no account be erected by unskilled or unsupervised labour.

If properly constructed it will give a high degree of protection against both blast and radiation. It can be designed to accommodate from six to 12 people and the cost will vary accordingly.



**Fig 23**

## Stocking your shelter

Life in the confined space of a survival shelter needs careful planning.

**You should store as much as possible of the following in your shelter:**

### Water

Water in sealed or covered containers to last you and your family for 14 days. Four pints per person per day would be sufficient for drinking and basic cleanliness.

### Food

Enough food for 14 days, including tinned or powdered milk for the children and food for the baby - and a closed cupboard or cabinet in which to store these supplies.

A nutritionally balanced diet is not important for this length of time. A list of suggested foods and quantities for one adult is given at the back of this booklet. These have been chosen because they store easily and most can be eaten cold.

Nursing mothers will need extra food and children between the ages of one and five years should be counted as half an adult for the purposes of food stocks. They should also have the equivalent in dried or evaporated milk of one pint of milk per day. If your family includes a baby that is not breast fed you should provide dried infant formula.

Alternatives to this are 7kg of full cream evaporated milk and 1/2kg sugar or 2 1/2kg full cream dried milk and 1/2kg sugar, which should be sufficient for two weeks. To this can be added mashed 'adult' foods if the infant is more than three or four months old.

### Radio

A portable radio (and a spare if possible) and spare batteries.

This is absolutely essential. It will be your only way of receiving instructions on when it is safe to leave your shelter and for how long. In the case of shelter types 3 and 4 an external aerial may be necessary.

### **Miscellaneous**

Tin opener, bottle opener, cutlery, crockery and cooking utensils.

Warm clothing and footwear and changes of clothing.

Bedding. sleeping bags, etc.

Torches with spare bulbs and batteries, candles and matches. Open flames should not be used in shelter types 3 and 4 until the shelter door can be opened.

Toilet articles and washbowls.

First aid kit.

Notebooks and pencils for noting radio instructions.

Cleaning materials: including cloths, tissues, brushes, shovels and box of dry sand.

Garden spade

Improvised lavatory seat, polythene buckets fitted with covers, polythene bag linings for emptying the contents, strong disinfectant and toilet paper. Alternatively camping or caravan type toilet arrangements may be used.

Clock and calendar.

### **and just outside your shelter**

Dustbin for temporary storage of waste matter.

Second dustbin for food remains. empty tins and other rubbish.

Polythene bag or bin for outdoor clothes and boots.

If possible. extra water supplies in covered containers, and games, children's toys and books.

Stoves burning liquid fuel or gas may be used at or just outside the entrance of shelter types 1, 1a and 2, or in a similar way in types 1b, 3 and 4 but only when it is safe to open the hatch or door. Otherwise you should not use a stove of this kind in a sealed shelter.

## **Suggested food list**

### **Supplies for two weeks for one adult**

Biscuits, crackers, breakfast cereals etc.	2750g (6 lb)*
--	---------------

Canned meat or fish (e.g. corned beef, luncheon meat, stewed steak, pilchards, sardines)	2000g (4¼ lb)
Canned vegetables (e.g. baked beans, carrots, potatoes, sweetcorn etc.)	1800g (4 lb)
Canned margarine or butter, or peanut butter	500g (1 lb)
Jam, marmalade, honey or spread	500g (1 lb)
Canned soups	6 cans
Full cream evaporated milk or dried milk	14 small cans or 2 x 300g(1/2 lb) containers
Sugar	700g (1 1/2 lb)
Tea or coffee (instant)	250g (1/2 lb)
Boiled sweets or other sweets	450g (1 lb)
Canned fruit, fruit juices, fruit squash, drinking chocolate	If sufficient storage space is available
<i>Approximate cost (mid 1980)</i>	£15-£20

\* Imperial equivalents are only approximate.

This list is based on the assumption that cooking will not be possible and that the opportunities for warming foods or boiling water may be limited. For further details see *Domestic Nuclear Shelters - Technical Guidance*.

## Protect and survive



# Keep this booklet handy

---

## Further reading

A booklet, *Nuclear Weapons* (ISBN 0 II 340557 X), published by Her Majesty's Stationery Office, is also available. It contains detailed information about the effects of nuclear weapons and will be of interest to those who wish to further their knowledge of the subject.

---

Prepared for the Home Office by the Central Office of Information 1981.

Printed in England for Her Majesty's Stationery Office by

Sackville Press (Billericay) Ltd.

ISBN 0 11 340737 8 K400 Dd716560

HMSO 50 pence (net)

First Published 1981

---



---

*This document is believed to be in the public domain and was transferred to the Internet by George Coney.*

*Last updated June 1999*

Send mail to [atomic@cybertrn.demon.co.uk](mailto:atomic@cybertrn.demon.co.uk)

---

# Domestic Nuclear Shelters

## Advice on domestic shelters providing protection against nuclear explosions



### A Home Office Guide

---

## Domestic Nuclear Shelters

This booklet is a brief guide to three basic kinds of nuclear shelter:

- Simple shelters for short-term indoor or out-door use which can be built from materials already at hand.
  - Shelters that can be assembled from do-it-yourself kits.
  - Permanent custom-built shelters built into the ground and requiring professional help in design and construction.
- 

### Further information

Additional information about protection from nuclear attack is to be found in the booklet [Protect and Survive](#) available from Her Majesty's Stationery Office and main booksellers or by post from HMSO bookshops.

Detailed technical guidance on shelter design and Construction is available in *Domestic Nuclear Shelters- Technical Guidance* published by HMSO. More detailed description of the effects of nuclear weapons can be found in *Nuclear Weapons* published by HMSO.

## The likely effects of a nuclear attack

### Light and heat

A nuclear explosion produces an intense flash of light lasting some seconds which would blind anyone seeing it. The heat flash can set fire to buildings up to some distance from the centre of the explosion depending upon the haziness of the atmosphere at the time. Skin exposed to the heat flash could suffer burns. But any shelter that withstands the blast would give protection against the heat flash. Any exposed parts of the shelter made of flammable material could catch fire. Exposed plastic would not catch fire but might distort in the heat and this could weaken the resistance of the shelter to the subsequent blast wave.



## Initial nuclear radiation (INR)

This very penetrating radiation is emitted from the fireball within one minute of the explosion. The distances from one megaton explosions and above, at which people require shielding from INR, are less than those distances at which there would be total destruction.

## Blast

At the moment of explosion a blast wave would be generated, travelling at a tremendous speed and creating extremely strong winds which may last for several seconds. When the blast wave passes over a building the sudden increase of pressure and the following wind may cause the building either to explode or collapse.

## Tremors

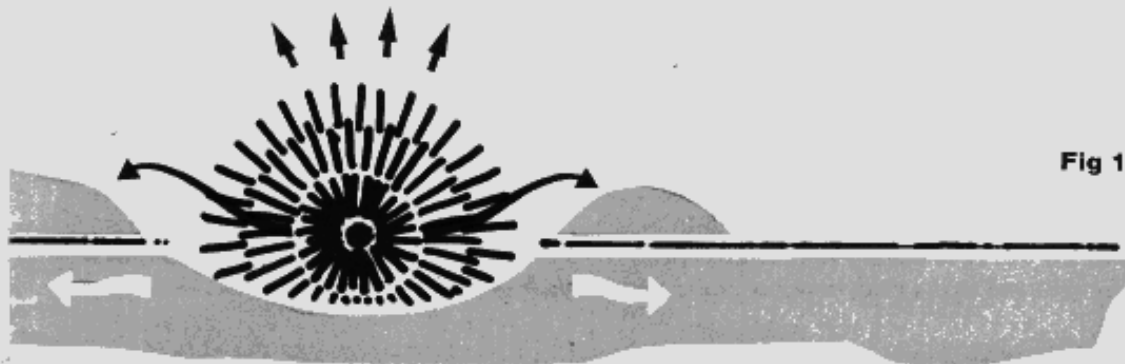
The tremors or shock waves from a ground blast extend for a short distance only and would not affect buildings beyond those already destroyed by the blast. The effect on shelters below the ground would depend on their ability to withstand ground movement and on the nature of the soil. Depth in the ground, shape and flexibility would be important.

## Fallout

An explosion on or near the ground sucks up a large amount of earth and debris, which is vaporised as it rises to a great height and becomes highly radioactive. It then condenses to sand-like particles which are carried along by the wind and drop to the ground. This fallout can come down very near to the explosion or may be carried by the wind for hundreds of miles. The fallout dust is usually visible to the naked eye, but it emits ionising radiation rather like X-rays, which cannot be seen or felt. Radiation is dangerous and heavy doses cause sickness or death. Fallout dust remains radioactive for some days after the explosion - and can, in certain circumstances, still be dangerous after several weeks.

## Bombs exploding on or near the ground

When a nuclear weapon explodes on or near the ground, a shock like a small earthquake goes through the ground. The earth vaporised into the fireball leaves a crater around the site of the explosion. The vaporised earth falls to the ground from half an hour to up to about a day later as radioactive fallout.



## Bombs exploding in the air

When a nuclear bomb explodes in the air the blast effect is more marked. The area affected will be about 30 per cent greater than a ground burst bomb of the same size. But with air-burst weapons there is no dangerous radioactive fallout - since the fireball does not touch the ground no earth is sucked up.

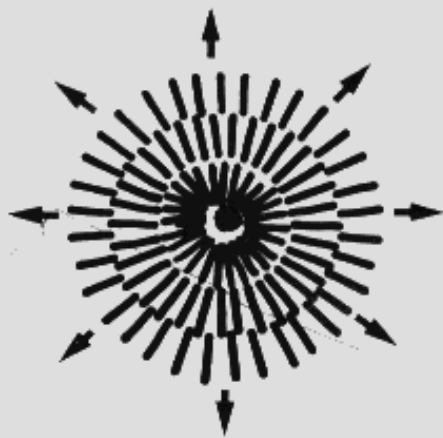
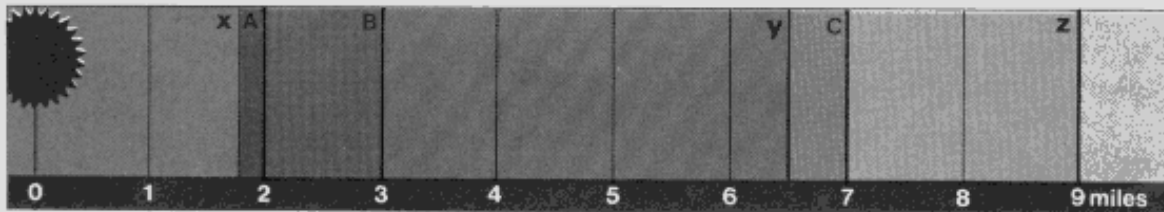


Fig 2

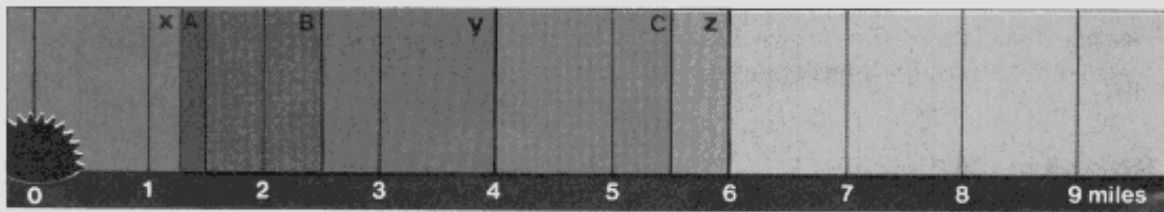


Fig 3 - The extent of blast, fire and INR effects

**Air burst (1 megaton)**



**Ground burst (1 megaton)**



- Limit of:    **A** Total destruction                      **x** Approx. range of INR within which shielding is vital                      **z** Blistering to exposed skin  
                  **B** Irreparable damage                      **y** Fire zone  
                  **C** Severe/moderate damage

## What happens to fallout after a nuclear attack

It is important to remember that the radiation emitted from fallout decreases as time passes, very rapidly at first and more slowly later. For example, after seven hours the radiation emitted will have fallen to one tenth of its strength and after two days to one hundredth.

When the intensity has fallen sufficiently it will be safe to emerge from your shelter for short periods. You will be advised by radio when this is, and for how long you can stay outside. At first it might be safe to spend only an hour or so a day in the open but this safe period will gradually increase until it becomes safe to stay outside all the time. Even in the worst affected areas it might be safe to leave the shelter altogether after about two weeks and in most places this period would be very much shorter.

When outside the shelter no special clothing is required, but it would be advisable to wear outdoor clothing and wellington boots or stout shoes to avoid contamination of your indoor clothes. You should remove these clothes before re-entering the shelter.

The shelters described later on in this booklet offer differing degrees of protection against blast and against fallout. They will also provide protection against the heat flash provided no flammable materials are exposed. No shelter is capable of protecting someone close to the site of a nuclear explosion, but for those who are far enough away to survive the initial effects. The principal danger after the explosion is from radioactive fallout.

Dense material around a shelter will lessen the risk of harm from radiation so long as you remain inside. Essentially the thicker the material the better the protection. But some protective materials are more effective than others.

Below is a list of common materials likely to be used in the construction of a shelter. Their value as protection against radiation is given in terms of the thickness required to reduce radiation by one half thus 2 in. of lead gives the same protection as 3 1/2 in. of slates.

The protection given by buildings or shelters can be expressed as a *protective factor*. A typical house will reduce the power of the radiation to one fifteenth of that outside - this is called a protective factor of 15. Shelters constructed of the right materials can give a much greater protective factor than this.

### Some relative protection values

	Inches		Inches	
LEAD	0.5	STONE	2.2	<b>Increased thicknesses of material reduce the intensity of ionising radiation. For example, each 2.2 in. of concrete reduces the intensity by half, so a thickness of 8.8 in. of concrete would reduce the radiation to one sixteenth of its original intensity.</b>
STEEL	0.7	BRICKWORK	2.8	
TILES	1.0 to 1.9	SAND	2.9	
CORRUGATED ASBESTOS SHEET	2.0	EARTH	3.3	
		PLASTER	3.5	
ASPHALT	2.2	SLATES	3.5	
CONCRETE	2.2	WOOD	8.8	

## The overall picture

If there were a nuclear attack, it is likely that some bombs might burst in the air, and some on or near the ground. Estimates suggest that around 5 per cent of the land area of the UK might suffer seriously from the effects of blast. We cannot, of course, know in advance where the bombs would fall, but about 80 per cent of the land area might suffer no blast effects at all. Any part of the country might suffer fallout therefore radiation protection would be needed everywhere.

## Types of shelters

The section that follows describes four different types of shelter, the kind of protection they offer, and where they can be sited. The examples illustrated are from the detailed designs in *Domestic Nuclear Shelters - Technical Guidance*. It may be possible to vary the materials or the methods of construction shown in this booklet, without reducing the degree of protection provided, but if you propose to do so, check that your shelter will still conform to the guidance in that publication. If you decide to consult someone about a shelter you should check that they are professionally qualified, preferably as an architect or chartered civil/structural engineer. The Home Office proposes to publish further designs later. These designs will probably include at least one using glass reinforced

plastic (fibre glass).

	<b>Type 1 Improvised</b>	<b>Type 2 Indoor kit</b>	<b>Type 3 Outdoor kit</b>	<b>Type 4 Purpose built</b>
Blast Protection psi (pounds per square inch)	Up to 1.5	Up to 6	Up to 11	In excess of 11
Fallout Radiation Protection Factor	Not less than 40	Not less than 70	Not less than 200	In excess of 300. Also protects against INR
Distance from a one megaton air burst beyond which shelter will remain intact	7 miles	3 miles	2 miles	Closer than 2 miles depending on design
Ventilation	Natural	Natural or forced	Forced	Forced
Site of installation	In house or garden	In house	In garden. Sectional for access through house	In garden. Appropriate access to garden necessary
Forethought and planning	<b>Install in crisis.</b> Some materials can be prepared in advance	Obtain in peace-time. <b>Install in crisis</b>	Obtain in peace-time. Install in peace time or crisis (Can be installed as a permanent shelter)	Install in peace-time using professional advice and help
Approximate expected cost (1980)	Nominal if using local materials: scaffold frame about £250	Kit £500-£800 Bricks £300	Kit £900-£1800 Plus any installation costs	£6000-£10,000 (but more sophisticated designs would obviously cost more)

- A garden shelter should preferably be at least half the height of the nearest house away to avoid debris from collapsed buildings. It should also be away from large trees. Before removing earth check that you cannot damage drainage or other services.

## Planning permission, Building Regulations and rating

If you wish to install a permanent shelter you may need permission. You should check the regulations *before submitting plans or beginning work*. Your local District Council will tell you about planning permission and the Building Regulations. A permanent shelter may affect the rateable value of your home, and this is a matter for your local District Valuer and Valuation Officer (Regional Assessor in Scotland).

## Type 1a

### Easily-constructed improvised garden shelter using household materials

This shelter is suitable for areas where under ground shelters are impracticable, for example, where there is a high water table, so that a deep hole fills with water. It can be constructed using only materials which are generally available, and could be *built in a time of crisis*. It would take two people about 24 working hours each to build.

The shelter consists of a shallow trench dug into the ground with a roof of doors or sheet timber that is supported above ground level by earth walls. The structure is then covered by at least 18 in. of earth.

This basic design will give good protection from fallout radiation particularly if the occupants keep away from the entrance area. If, in addition, a barrier of sandbags or packed soil is built about two feet in front of the entrance, and to the same height, the protection in the entrance area will be improved.

### Construction

1. Select a site on level ground where there is little chance of rainwater collecting.

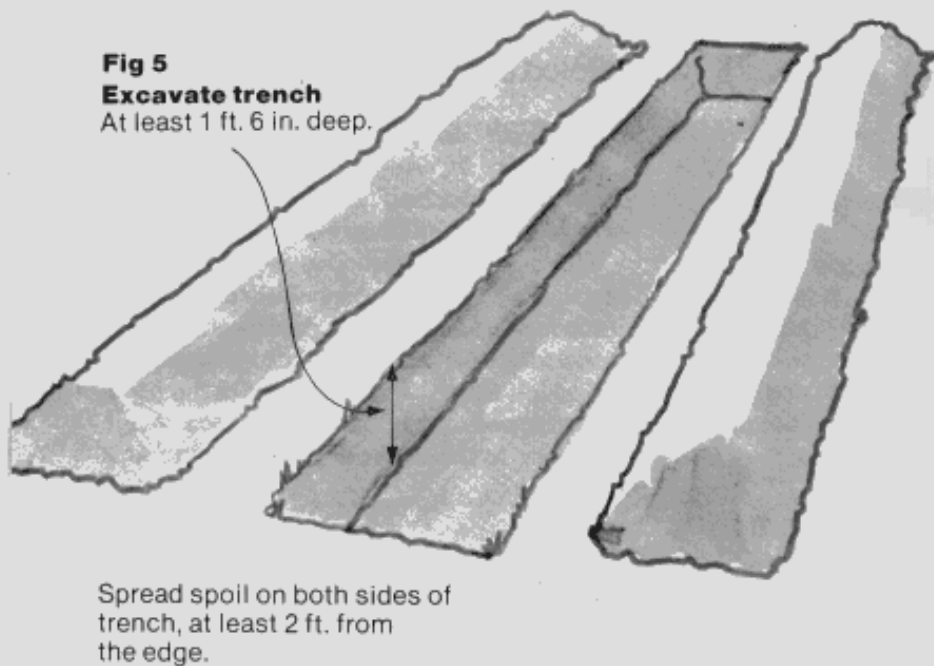
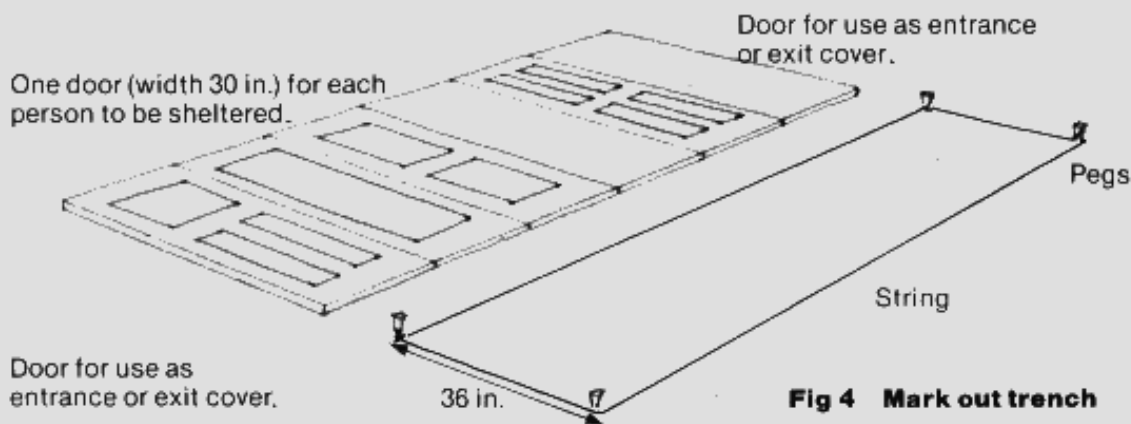
2. You will need:

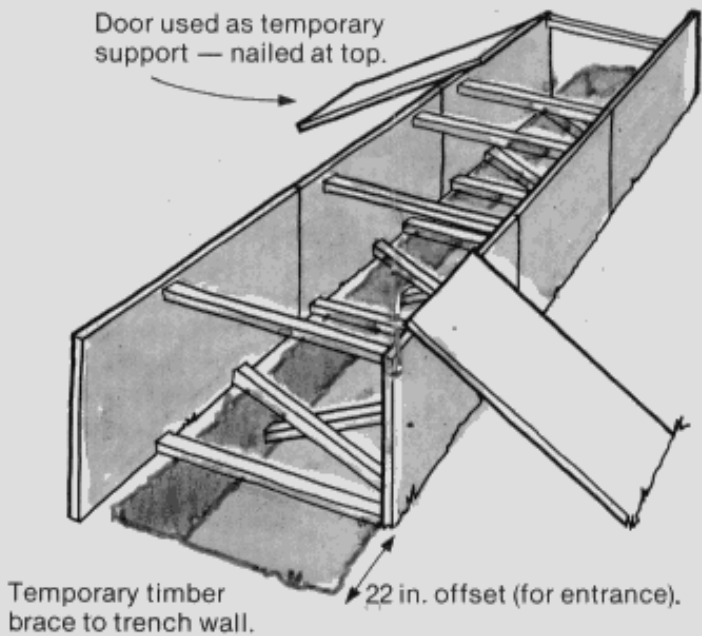
- i. Pick, shovel or spade (preferably both), wheelbarrow or buckets, saw, screw-driver, knife, tape measure, pencil and paper, and a pair of gloves.

- ii. Pieces of large sheeting material. e.g. carpets. blankets. sheets, heavy duty polythene, sacking etc. for making earth rolls (Fig 7).
- iii. Plastic bags or pillowcases for making sandbags.
- iv. Timber: pieces of 2 in. x 4 in. wood at least 3 ft long are must useful although any suitable strong timber could be used for the cross braces (Fig 6). Floor-boards about 4 ft long could be used for entrance and exit tunnels (Fig 13).
- v. Nails: 100 x 2 in. steel nails, 30 x 4 in. steel nails.
- vi. Doors: one door (normally about 30 in. wide) per person is required, together with one door each for entrance and exit. Fittings such as handles should be removed. If you do not have enough doors, sheet timber can be used.
- vii. Rainproofing material to cover the doors, e.g. polythene sheeting, shower curtains and vinyl floorcovering .
- viii. Pegs and string for markers and tying sandbags.

3. Construct the shelter as shown in Figs 4-14.

4. Furnish the shelter as required.

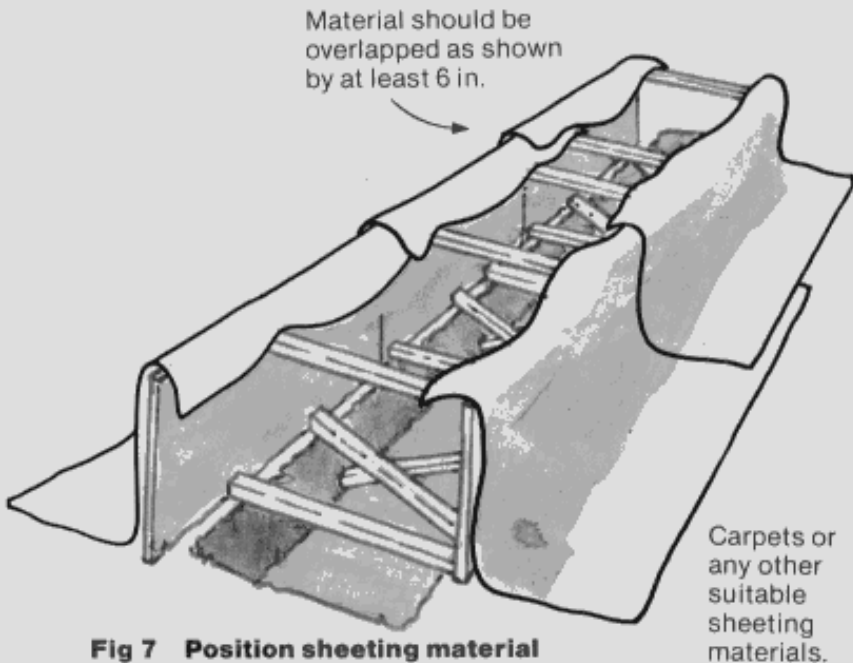




**Fig 6 Construct temporary walls**

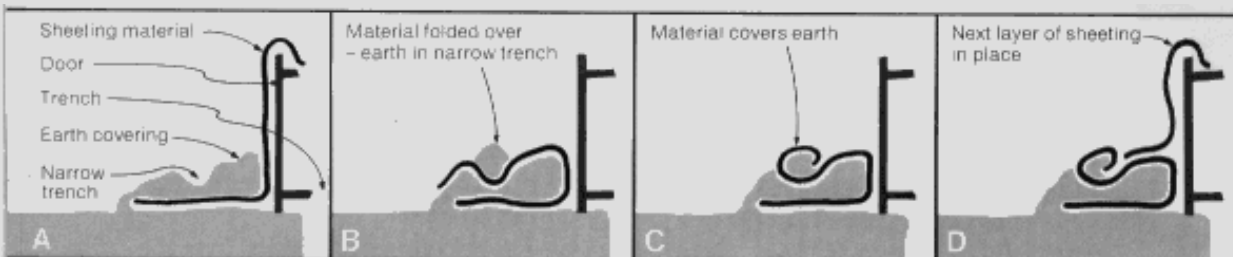
40 in. by 2 in. temporary timber braces between doors.

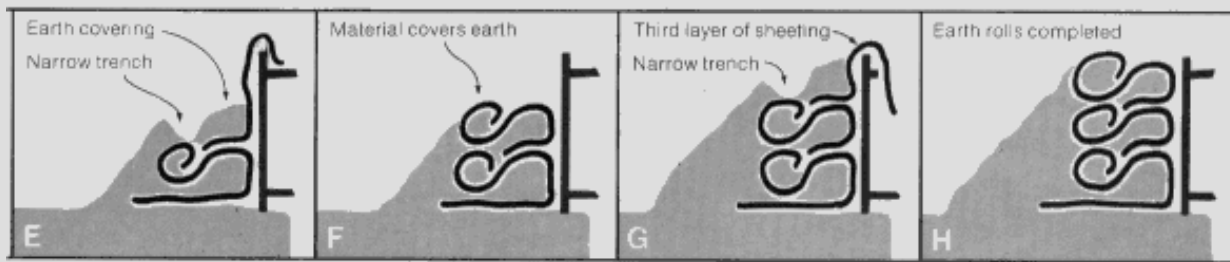
Doors in position - construct temporary supporting structure of doors and timber against which earth rolls can be built (frame is removed later and doors, then used to form a roof).



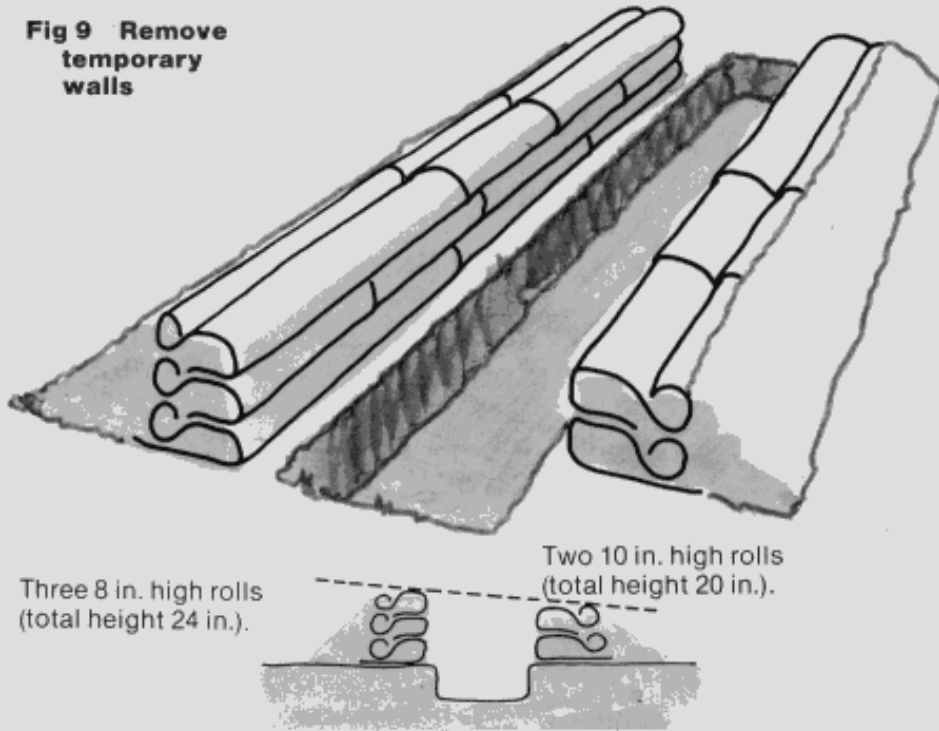
**Fig 7 Position sheeting material**

**Fig 8 - Construction of earth rolls**

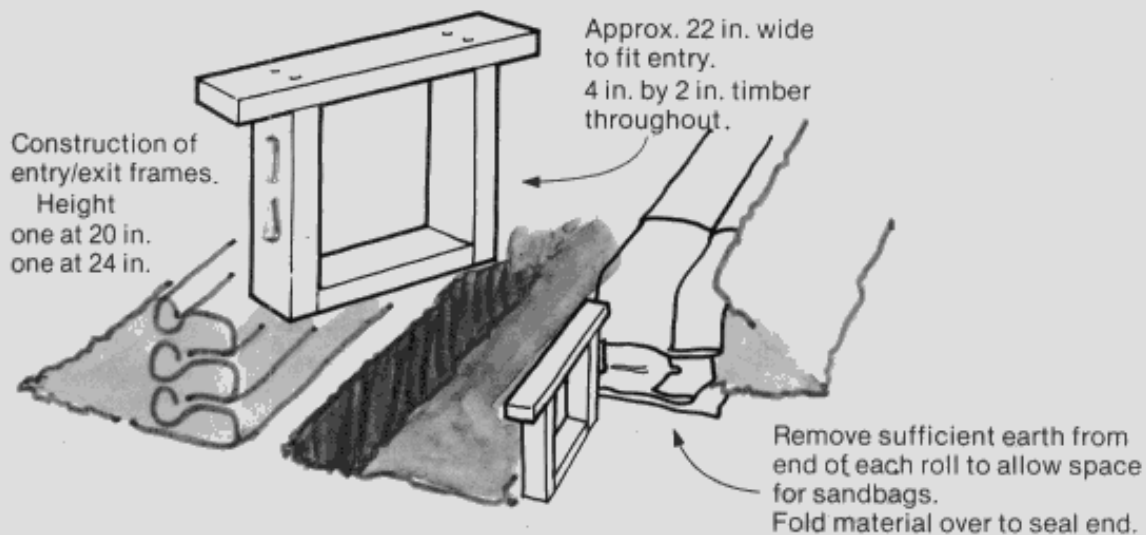




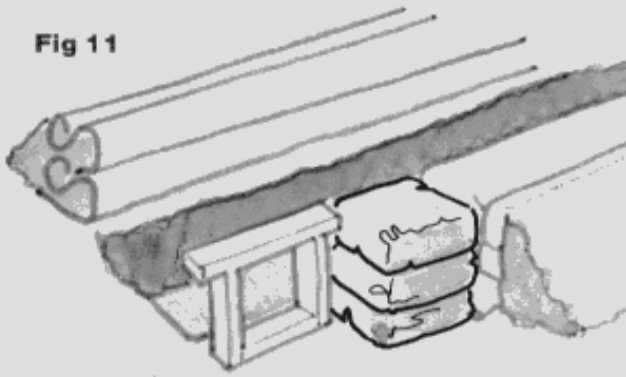
**Fig 9 Remove temporary walls**



**Fig 10 Construct entry/exit frames**

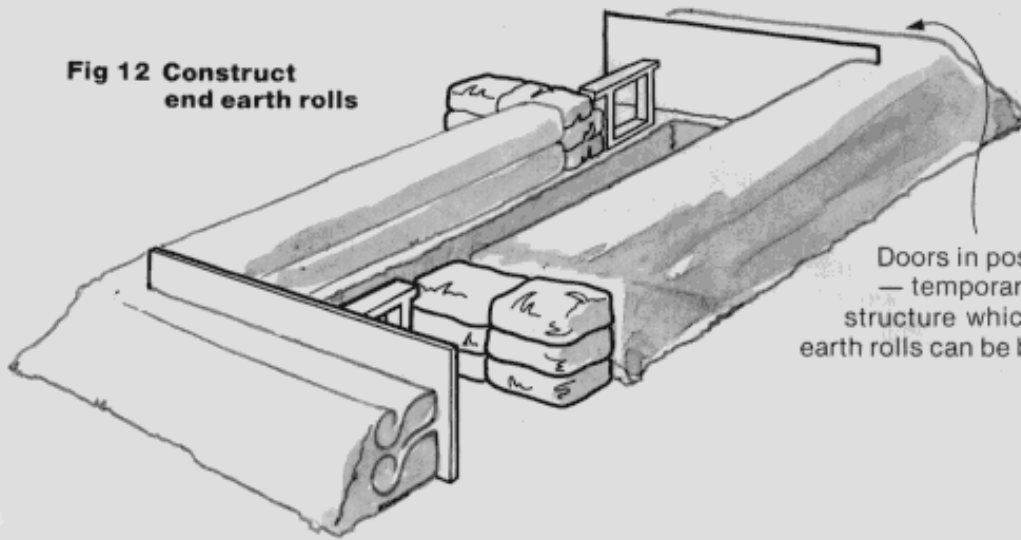


**Fig 11**



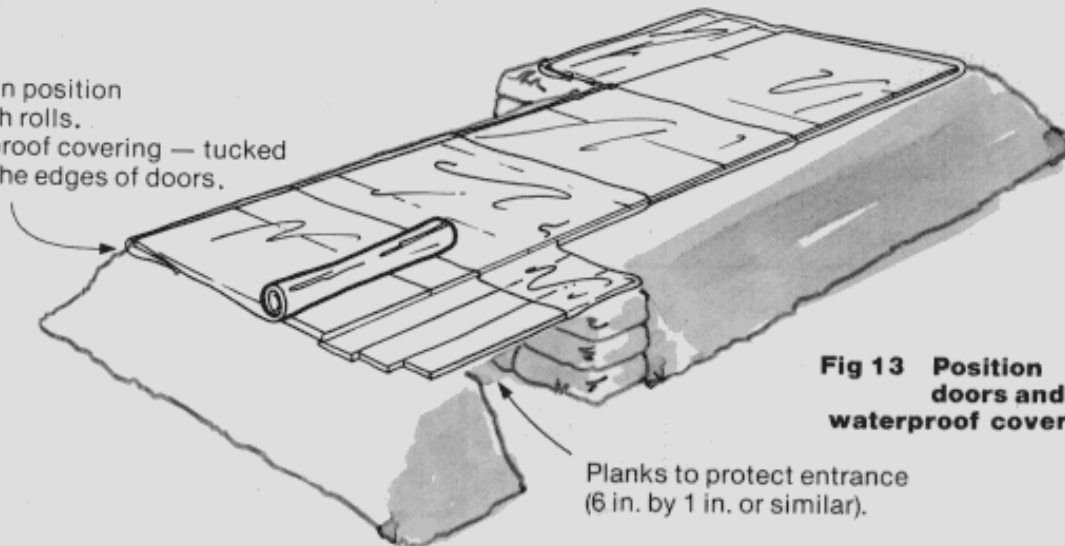
Sandbags will hold material in folded position.

**Fig 12 Construct end earth rolls**



Doors in position — temporary supporting structure which end earth rolls can be built against.

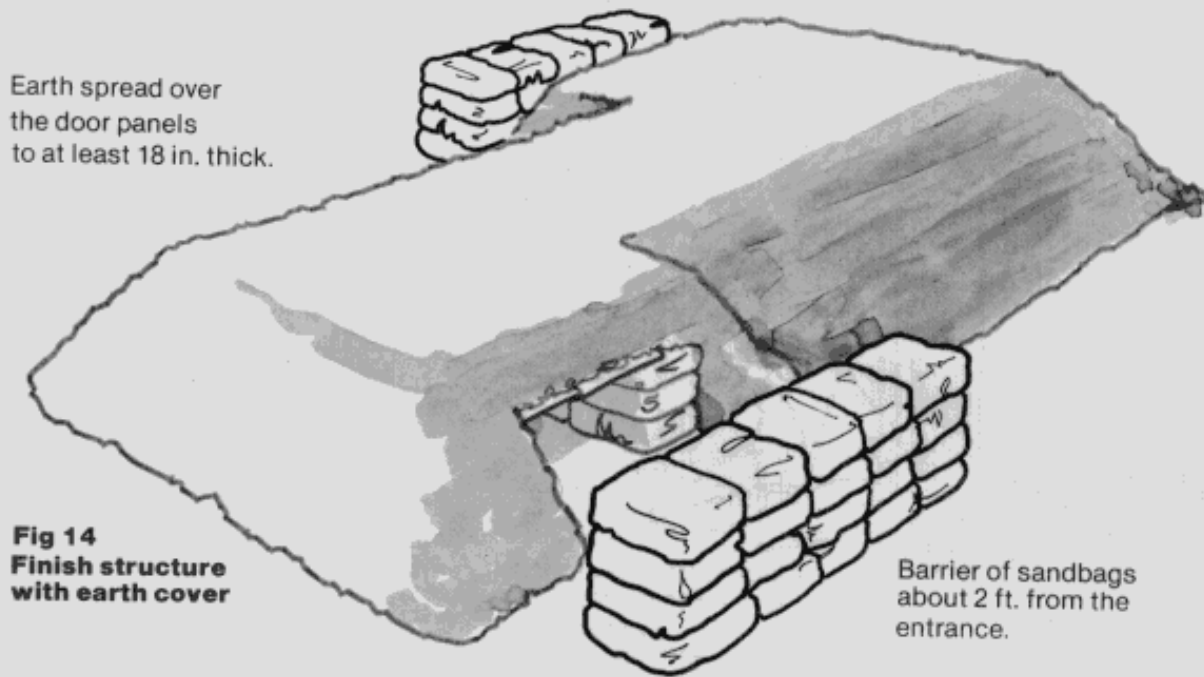
Doors in position on earth rolls. Waterproof covering — tucked under the edges of doors.



**Fig 13 Position doors and waterproof cover**

Planks to protect entrance (6 in. by 1 in. or similar).





## Type 1b

### Improvised outdoor shelter using do-it-yourself materials

The following diagrams show how a basic shelter can be constructed from standard scaffold poles and other materials available from builders merchants, timber yards and do-it-yourself stores.

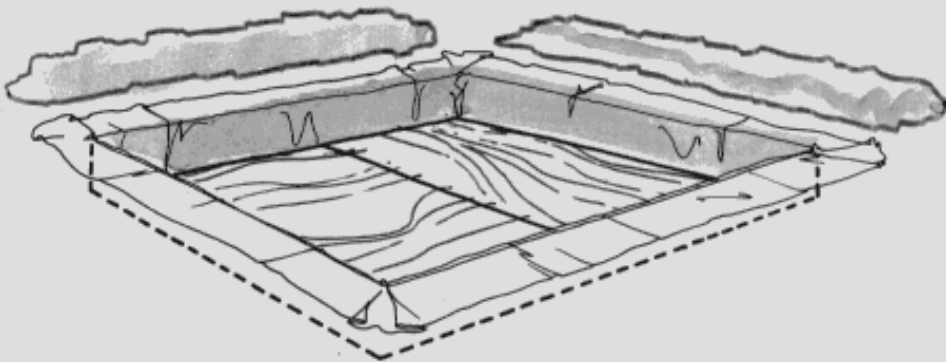
This type of shelter could be constructed in a time of crisis from materials previously purchased and stored. It would take two people about 24 working hours each to build this shelter - the size is adaptable.

The dimensions given would accommodate a family of four for a short period or two people plus provisions for longer.

This shelter uses steel or alloy, standard diameter scaffold poles. These are arranged in a series of 'A' frames over a trench. It is necessary to brace the frames with further scaffolding both diagonally along its length and across the waists of the 'A' sections to give rigidity. In both cases proprietary clamps are the best method of securing the scaffold poles to each other.

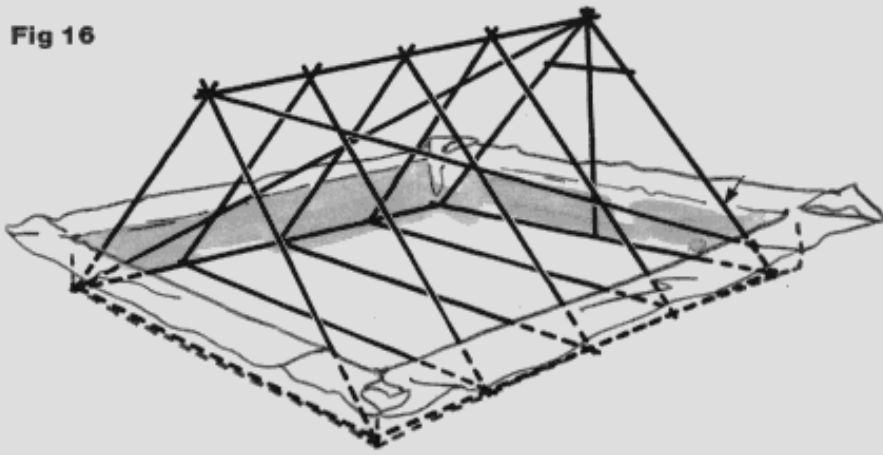
Prepare a trench 8 ft. x 8 ft. and at least 1 ft. 6 in. deep. Line it with heavy duty polythene sheeting. Lay a floor of two sheets of plywood, 3/4 in. thick and 4 ft. x 8 ft.

Fig 15



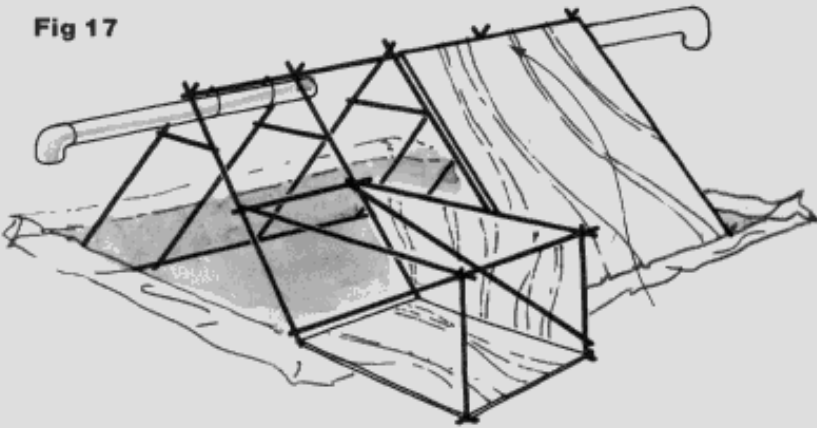
Construct the frame of scaffold poles (or you could use wood). This should be as strong as you can make it. You can increase the strength with vertical and diagonal bracing, or crossbars.

Fig 16



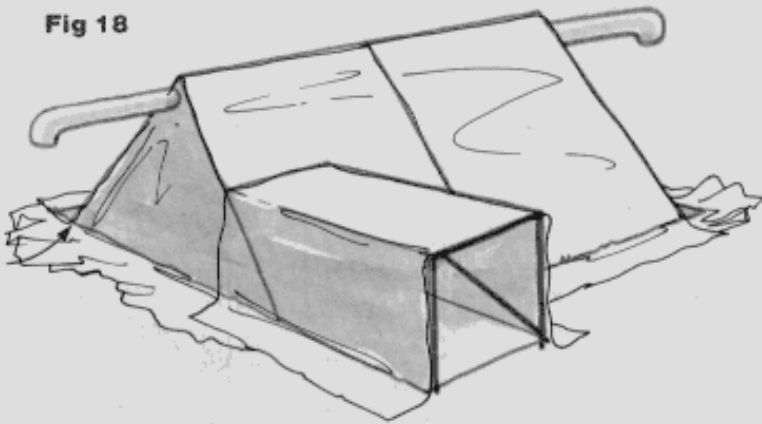
Add the frame for the entrance tunnel, and also the ventilation pipe (described opposite). Cover the entire frame (except the entrance hole) with plywood boarding. Any small gaps or sharp edges should be covered with carpet or thick fabric.

Fig 17



Wrap the shelter with overlapping sheets of heavy duty polythene. Make sure the trench lining is within this cover.

Fig 18



Finally, cover the shelter with a thick layer of earth (about 18 in.). The earth removed from the trench may not be enough for this. If you decide to dig a deeper initial trench to get enough earth to cover, you may need to make some modifications to the design given here.

The shelter will give better blast protection if you put a layer of resilient material between the polythene and the earth covering. Straw, mattresses, or similar, would be suitable.

The entrance can be filled from within with small bags of sand or earth. You will have to store these inside the shelter.

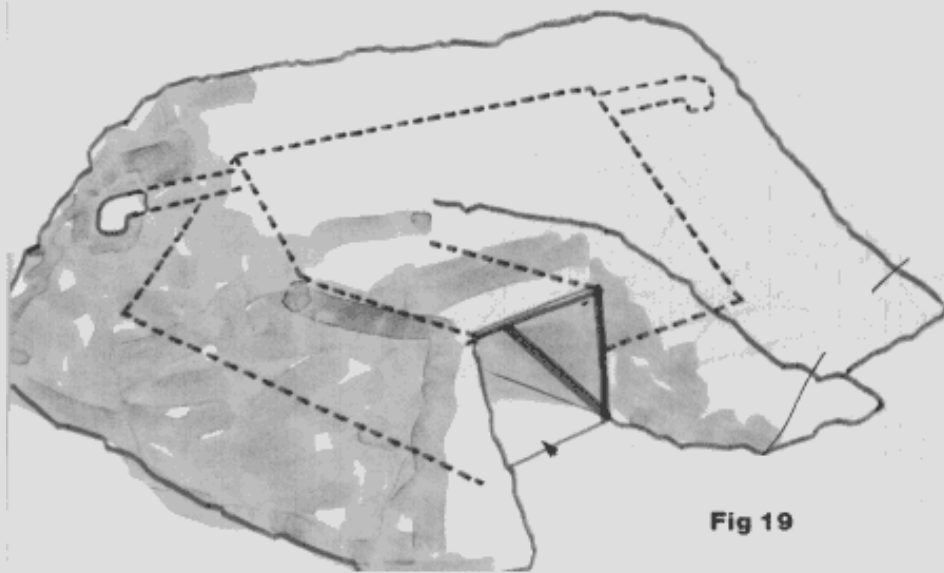
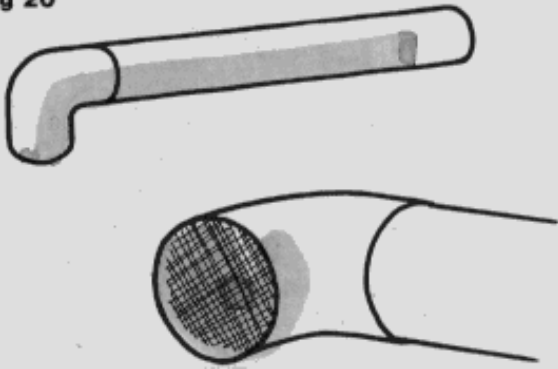


Fig 19

## Ventilation

For this shelter you will need to make some provision for ventilation. The diagrams show metal drainpipes with a bend near the opening, so that this faces downward. The opening should then be filled with a filter of steel wool. It is extremely important to ensure that ventilation pipes are secure and kept free of obstruction.

Fig 20



The following two designs are intended to be sold by manufacturers as kits together with installation instructions. Design drawings are to be found in *Domestic Nuclear Shelters - Technical Guidance*.

## Type 2

### Indoor shelter from manufactured kit

This type of shelter - basically a protective steel table - is suitable for homes that have basements or rooms that can be converted into 'fallout rooms' (described in *Protect and Survive*) provided that the floor is strong enough to support it.

This shelter will sustain the debris load resulting from the complete collapse of a normal two-storey house. To obtain protection from fallout, it must be surrounded with dry-laid bricks, sand or earth bags or heavy furniture filled with sand, earth or books.

The shelter is designed to accommodate two adults and two children. Two shelters or more may be put together to increase the capacity.

It would take two people about two hours to erect the shelter itself and up to an additional 20 hours to surround it with protective material.

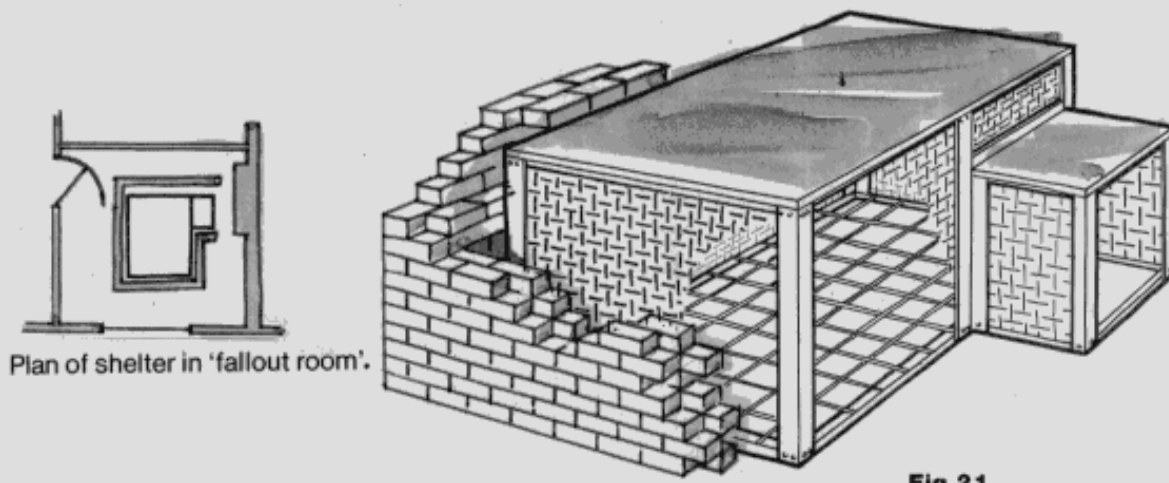


Fig 21

## Type 3

### Outdoor shelter from a manufactured kit

This type of shelter is generally suitable where there is a garden or other convenient land near the living accommodation. It is formed by building a strong structural shell with prefabricated steel components bolted together to form a sealed room of sufficient size for up to six people. The shell is semi-sunk in the ground and covered entirely by earth from the excavation. There will be variations both in materials and construction depending upon the costs. The assembly of the shell would take a full days work for two people. The excavation could, however, take at least a week for two people digging by hand. While the kit could be bought in readiness and digging and installation done over a period of time the materials would have to be non-corrosive, and not likely to deteriorate.

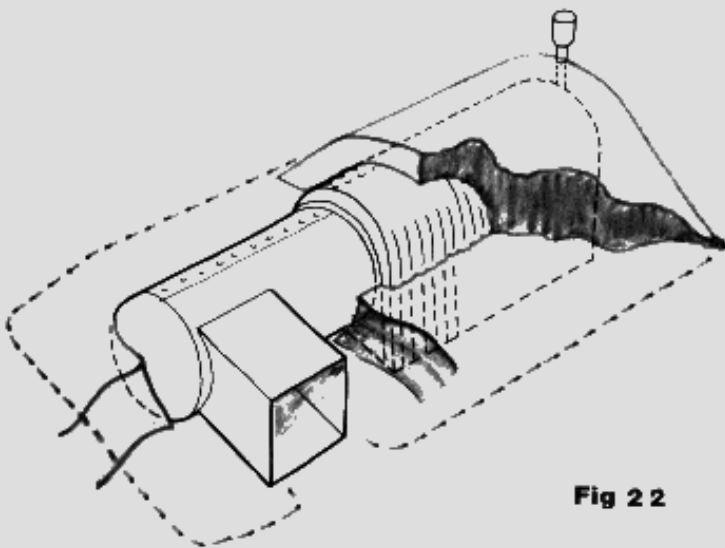
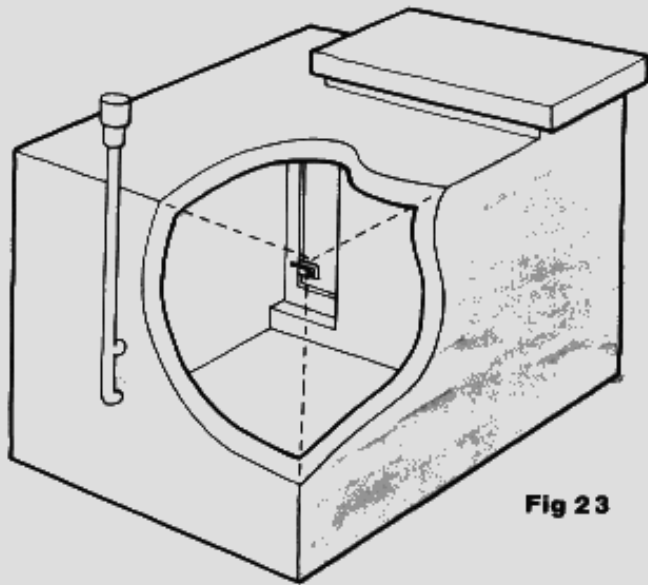


Fig 22

## Type 4

### Permanent purpose-built shelter

This reinforced concrete shelter must be erected by a building contractor under the guidance of a chartered civil/structural engineer. It should on no account be erected by unskilled or unsupervised labour. If properly constructed it will give a high degree of protection against both blast and radiation. It can be designed to accommodate from six to 12 people and the cost will vary accordingly.



**Fig 23**

## Stocking your shelter

Life in the confined space of a survival shelter needs careful planning.

**You should store as much as possible of the following in your shelter:**

### Water

Water in sealed or covered containers to last you and your family for 14 days. Four pints per person per day would be sufficient for drinking and basic cleanliness.

### Food

Enough food for 14 days, including tinned or powdered milk for the children and food for the baby - and a closed cupboard or cabinet in which to store these supplies.

A nutritionally balanced diet is not important for this length of time. A list of suggested foods and quantities for one adult is given at the back of this booklet. These have been chosen because they store easily and most can be eaten cold.

Nursing mothers will need extra food and children between the ages of one and five years should be counted as half an adult for the purposes of food stocks. They should also have the equivalent in dried or evaporated milk of one pint of milk per day. If your family includes a baby that is not breast fed you should provide dried infant formula.

Alternatives to this are 7kg of full cream evaporated milk and 1/2kg sugar or 2 1/2kg full cream dried milk and 1/2kg sugar, which should be sufficient for two weeks. To this can be added mashed 'adult' foods if the infant is more than three or four months old.

### Radio

A portable radio (and a spare if possible) and spare batteries.

This is absolutely essential. It will be your only way of receiving instructions on when it is safe to leave your shelter and for how long. In the case of shelter types 3 and 4 an external aerial may be necessary.

### Miscellaneous

Tin opener, bottle opener, cutlery, crockery and cooking utensils.

Warm clothing and footwear and changes of clothing.

Bedding, sleeping bags, etc.

Torches with spare bulbs and batteries, candles and matches. Open flames should not be used in shelter types 3 and 4 until the shelter door can be opened.

Toilet articles and washbowls.

First aid kit.

Notebooks and pencils for noting radio instructions.

Cleaning materials: including cloths, tissues, brushes, shovels and box of dry sand.

Garden spade

Improvised lavatory seat, polythene buckets fitted with covers, polythene bag linings for emptying the contents, strong disinfectant and toilet paper. Alternatively camping or caravan type toilet arrangements may be used.

Clock and calendar.

### **and just outside your shelter**

Dustbin for temporary storage of waste matter.

Second dustbin for food remains, empty tins and other rubbish.

Polythene bag or bin for outdoor clothes and boots.

If possible, extra water supplies in covered containers, and games, children's toys and books.

Stoves burning liquid fuel or gas may be used at or just outside the entrance of shelter types 1, 1a and 2, or in a similar way in types 1b, 3 and 4 but only when it is safe to open the hatch or door. Otherwise you should not use a stove of this kind in a sealed shelter.

## **Suggested food list**

### **Supplies for two weeks for one adult**

Biscuits, crackers, breakfast cereals etc.	2750g (6 lb)*
Canned meat or fish (e.g. corned beef, luncheon meat, stewed steak, pilchards, sardines)	2000g (4¼ lb)
Canned vegetables (e.g. baked beans, carrots, potatoes, sweetcorn etc.)	1800g (4 lb)
Canned margarine or butter, or peanut butter	500g (1 lb)
Jam, marmalade, honey or spread	500g (1 lb)
Canned soups	6 cans
Full cream evaporated milk or dried milk	14 small cans or 2 x 300g(1/2 lb) containers
Sugar	700g (1 1/2 lb)
Tea or coffee (instant)	250g (1/2 lb)
Boiled sweets or other sweets	450g (1 lb)
Canned fruit, fruit juices, fruit squash, drinking chocolate	If sufficient storage space is available
<i>Approximate cost (mid 1980)</i>	£15-£20

\* Imperial equivalents are only approximate.

This list is based on the assumption that cooking will not be possible and that the opportunities for warming foods or boiling water may be limited. For further details see *Domestic Nuclear Shelters - Technical Guidance*.

# Protect and survive



## Keep this booklet handy

---

### Further reading

A booklet, *Nuclear Weapons* (ISBN 0 II 340557 X), published by Her Majesty's Stationery Office, is also available. It contains detailed information about the effects of nuclear weapons and will be of interest to those who wish to further their knowledge of the subject.

---

Prepared for the Home Office by the Central Office of Information 1981.  
Printed in England for Her Majesty's Stationary Office by  
Sackville Press (Billericay) Ltd.  
ISBN 0 11 340737 8 K400 Dd716560

HMSO 50 pence (net)

First Published 1981

---



---

*This document is believed to be in the public domain and was transferred to the Internet by George Coney.*  
*Last updated June 1999*  
Send mail to [atomic@cybertrn.demon.co.uk](mailto:atomic@cybertrn.demon.co.uk)

---